

# Cisco Room Panorama and Room 70 Panorama

## Room Preparation Guidelines



This document outlines the basic guidelines for a successful installation and use of the *Cisco Room Panorama* system.

In short, these guidelines deal with room design, room size, tables and seating, acoustic guidelines and microphone placement, and lighting.

Also, information that you need in order to prepare the room for the physical installation is included, such as system size and weight, how the system is fastened to the wall, and power and Ethernet requirements.

# Table of Contents

<b>Part 1: Room considerations</b> .....	<b>2</b>	Microphone guidelines.....	27
Room design considerations.....	3	Table microphones .....	28
Recommended room size.....	4	Table microphones on tapered Panorama tables .....	30
Content screen above the main screens .....	4	Table microphones on a classic video conferencing table.....	32
Content screen below the main screens .....	7	Table microphones on non-Panorama tables .....	33
Re-using a CTS, TX, or IX immersive room for Panorama.....	9	Ceiling microphones .....	35
<b>Part 2: Tables and seating</b> .....	<b>10</b>	Acoustic guidelines at a glance .....	36
Tables and seating.....	11	<b>Part 5: Lighting and HVAC</b> .....	<b>37</b>
Tables .....	11	Lighting guidelines .....	38
Seating.....	13	Heating, ventilation and air-conditioning .....	41
Table and seating for a classic video conferencing room .....	14	<b>Part 6: Appendices</b> .....	<b>42</b>
<b>Part 3: Wall preparation</b> .....	<b>15</b>	Room dimensions for Room Panorama.....	43
Preparing the wall .....	16	Room dimensions for Room Panorama in an IX5000 room .....	51
Horizontal rails.....	17	Room dimensions for Room 70 Panorama .....	52
Vertical risers .....	18	Room dimensions for Room 70 Panorama in an IX5000 room .....	64
Wall panels.....	19	Cosmetic wall panel finish .....	66
Power and Ethernet .....	20	Building a custom wall .....	67
Power.....	20	Additional requirements for a custom wall .....	67
LAN/Ethernet .....	20	Depth and width of the wall .....	68
Location of sockets.....	20	Subwoofer output and air flow .....	69
<b>Part 4: Acoustic guidelines</b> .....	<b>21</b>	Fastening the custom wall to the risers.....	70
Acoustic room guidelines.....	22	Color .....	70
Reverberation time.....	23	Lighting example.....	71
Sound absorption.....	24	PowerBalance from Signify.....	71
Noise levels.....	25	Recommended vendors .....	72
Sound insulation.....	25		
Examples of acoustic optimization solutions.....	26		

# Part 1: Room considerations

# Room design considerations

We have developed a set of guidelines how you can create a premium and comfortable room for conferencing and local meetings. Amongst other, we have considered the product itself, the room in which it is used, the table shape, color, and finish when designing the premium Room Panorama experience.

*Each customer is unique. It is important to involve the local workplace resources team and a Cisco certified integrator to refine details of the set-up. Our drawings don't consider where the room entrance is, and some customers may have special universal design and accessibility requirements. It is important to take into account the holistic integration, and avoid combining our room elements in a way that compromise accessibility.*

## **New Panorama generation**

The new *Cisco Room Panorama* and *Room 70 Panorama* are designed to make your video conferencing room more versatile and flexible also for local meetings.



We have designed tables that ensure good communication locally in the room as well as to remote conference participants. Everybody has a good view of the content screen, which is placed above the main screens\*.



## **Classic video conferencing room**

The *Cisco Room 70 Panorama* and *Cisco Room Panorama (low ceiling option)*\* also supports the classic video conferencing room.

We have designed tables to support the traditional video conferencing use case, with users sitting shoulder to shoulder, facing the system. In this set-up, the content screen is placed below the main screens.



\* *Cisco Room Panorama, low ceiling option*: The low ceiling option allows for flexible content screen placement. It does require you to work closely with a Cisco certified AV integrator to find a technical solution that works for you. The additional guidelines and requirements that applies to the low ceiling option is available online. Look for *Cisco Room Panorama Additional Guidelines and Requirements for Low Ceiling Option* at <https://www.cisco.com/go/panorama-installation>

# Recommended room size (page 1 of 5)

The recommended room size depends on the video system and the chosen table.

## Content screen above the main screens

We recommend three table widths to accommodate different office spaces. All tables are tapered.

- ▶ Maximum table width 2.5 m (98.4 in.)
- ▶ Maximum table width 2.2 m (86.6 in.)
- ▶ Maximum table width 1.9 m (74.9 in.)  
(not recommended for Room Panorama;  
only for Room 70 Panorama)

Read more in the "[Tables and seating](#)" chapter.

## Room width

We have defined three levels of space surrounding the system and table, and we allocate more width for the meeting participants in rooms with larger tables.

The room width for the different levels of surrounding space for *Room Panorama* is shown in the illustration.

- **Premium room size:** The premium room size is adding extra space around the product and the table to ensure a spacious and comfortable experience.
- **Standard room size:** The standard room size is fulfilling accessibility requirements.
- **Minimum room size:** The minimum room size compromise some level of accessibility, while maintaining the product experience.

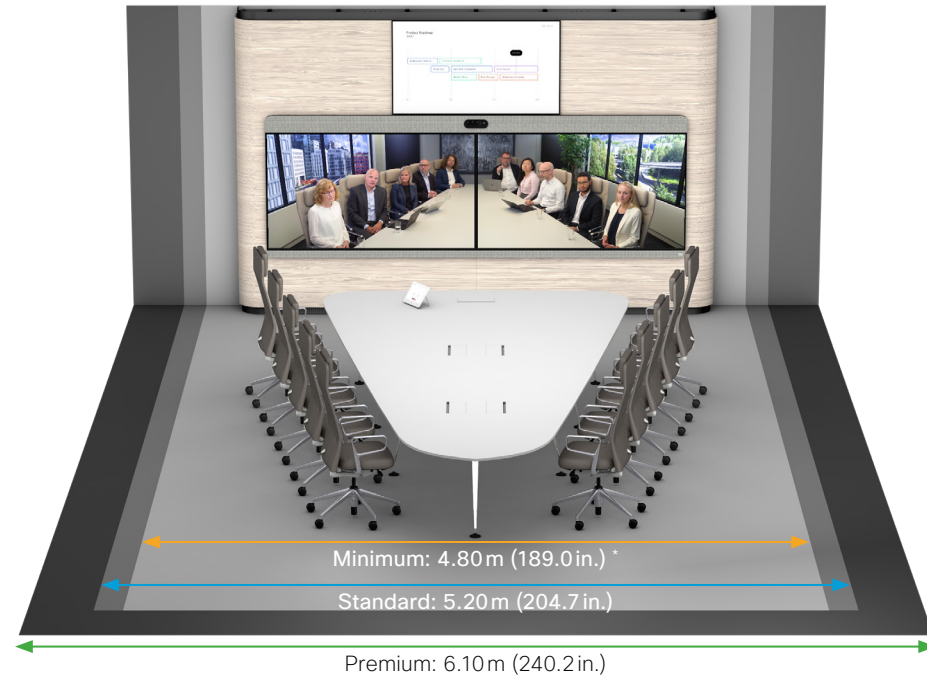

\* For *Room 70 Panorama* we allow a minimum room size of 4.20m (165.5 in.) for the smaller tables (6 and 8 persons).

# Recommended room size (page 2 of 5)

## Room length

The length of the room depends on the size of the table and if you want the premium, standard or minimum room size. We offer tables for 6, 8, 10, 12, or 14 persons.

## Room height

The ceiling height must be minimum 2.70m (106.3in.) to allow for the 65" content screen above the main screens.

## Recommended tables

Table 1 and Table 2 summarize the recommended room sizes\* and tables for *Room Panorama* and *Room 70 Panorama*, respectively. Both systems with the content screen mounted above the main screens.

**Table 1: Room Panorama, content screen above the main screens**

Table size	Room size - width × length [m (inch)]		
	Minimum room	Standard room	Premium room
6 persons	4.8 × 6.5 (189.0 × 255.9)	5.2 × 6.5 (204.7 × 255.9)	6.1 × 7.0 (240.2 × 275.6)
8 persons	4.8 × 7.3 (189.0 × 287.4)	5.2 × 7.3 (204.7 × 287.4)	6.1 × 7.8 (240.2 × 307.1)
10 persons	4.8 × 8.2 (189.0 × 322.8)	5.2 × 8.2 (204.7 × 322.8)	6.1 × 8.7 (240.2 × 342.5)
12 persons	4.8 × 9.0 (189.0 × 354.3)	5.2 × 9.0 (204.7 × 354.3)	6.1 × 9.5 (240.2 × 374.0)
14 persons	4.8 × 9.9 (189.0 × 389.8)	5.2 × 9.9 (204.7 × 389.8)	6.1 × 10.4 (240.2 × 409.4)

Recommended table width: 2.2m      Recommended table width: 2.5m

**Table 2: Room 70 Panorama, content screen above the main screens**

Table size	Room size - width × length [m (inch)]		
	Minimum room	Standard room	Premium room
6 persons	4.2 × 6.2 (165.5 × 244.1)	5.2 × 6.2 (204.7 × 244.1)	6.1 × 6.7 (240.2 × 265.1)
8 persons	4.2 × 7.1 (165.5 × 278.1)	5.2 × 7.1 (204.7 × 278.1)	6.1 × 7.6 (240.2 × 297.8)
10 persons	4.8 × 7.9 (189.0 × 311.0)	5.2 × 7.9 (204.7 × 311.0)	6.1 × 8.4 (240.2 × 330.7)
12 persons	4.8 × 8.7 (189.0 × 343.4)	5.2 × 8.7 (204.7 × 343.4)	6.1 × 9.2 (240.2 × 363.1)
14 persons	4.8 × 9.6 (189.0 × 376.9)	5.2 × 9.6 (204.7 × 376.9)	6.1 × 10.1 (240.2 × 396.6)

Recommended table width: 1.9m      Recommended table width: 2.2m      Recommended table width: 2.5m

\* All dimensions are after adding acoustic treatment to the walls.

## Recommended room size (page 3 of 5)

### **Table position**

Align the table to the product centerline, and place it 1.5 m (59.1 in.) from the system.

Read more in the "[Tables and seating](#)" chapter.

### **Avoid objects along the product centerline**

For the best viewing experience, we recommend that you avoid placing objects along the center line of the product, neither on the table, on the rear wall, or otherwise in the room. Also avoid wall patterns crossing the center line, and people sitting at the end of the table.

We have optimized the system to show people at a natural size. The two camera lenses are adjusted so that objects at the rear table edge appear with natural width. Closer to or further away from the camera, the image will be slightly distorted around the centerline:

- As you get closer to the camera, objects close to the center line will appear in both camera views.
- As you move further away, objects close to the centerline will not be fully captured.

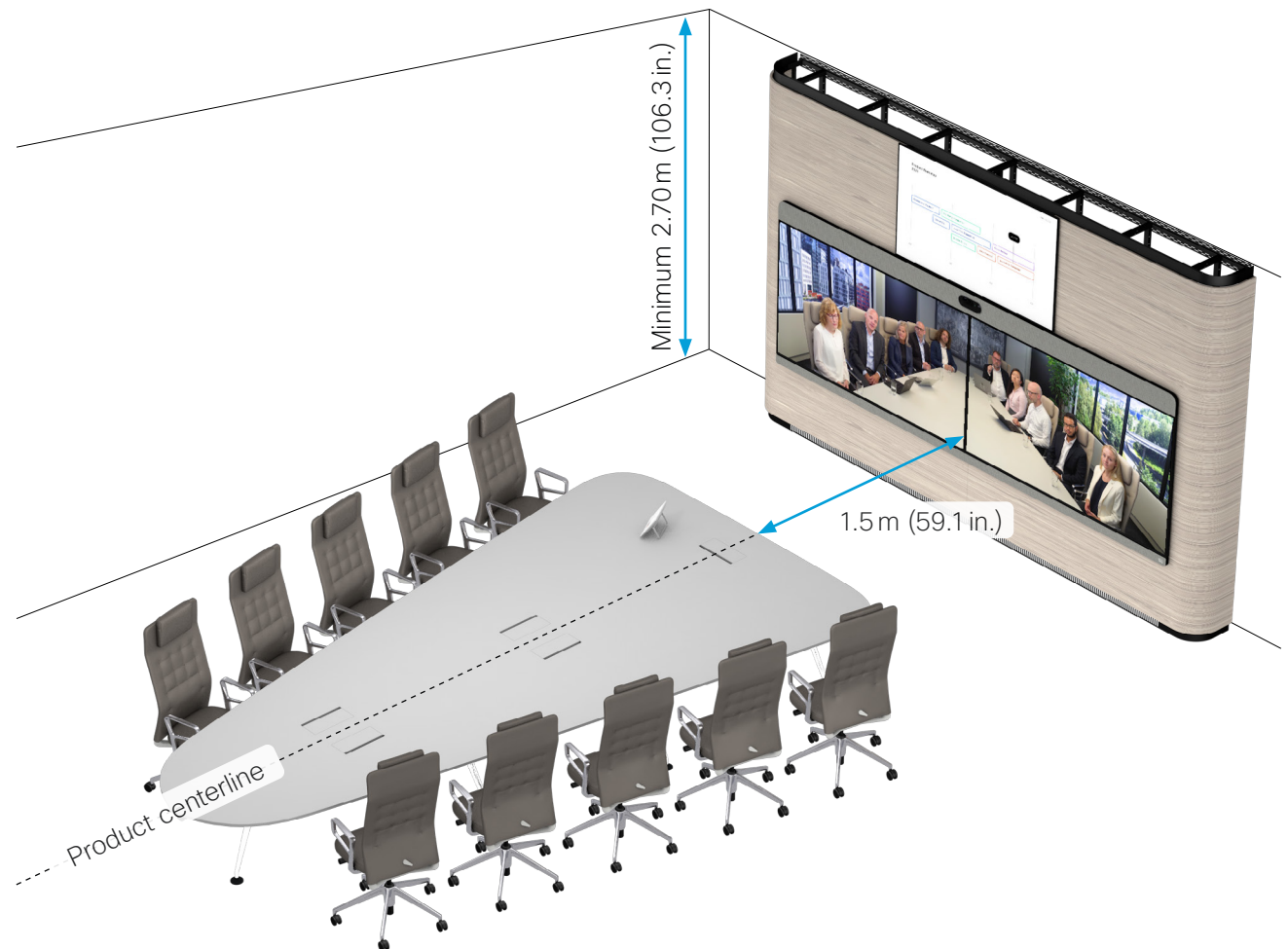

# Recommended room size (page 4 of 5)

## Content screen below the main screens

We have designed tailored tables for the classic video conferencing room where users are sitting shoulder to shoulder, facing the video system. The content screen is below the main screens.

We recommend two table sizes to accommodate different office spaces. Both tables are for 6 persons.

 Small classic table: Width 4.2 m (165.4 in.)

 Large classic table: Width 4.8 m (189.0 in.)

Read more in the "[Tables and seating](#)" chapter.

**Note:** Only *Room 70 Panorama* and the *Room Panorama Low Ceiling option* support a classic video conferencing room with the content screen below the main screens.

## Room size







Just as for the tapered tables, we have defined three levels of space surrounding the system and table, and we allocate more width for the meeting participants in rooms with larger tables.

- **Premium room size:** The premium room size is adding extra space around the product and the table to ensure a spacious and comfortable experience.
- **Standard room size:** The standard room size is fulfilling accessibility requirements.
- **Minimum room size:** The minimum room size compromise some level of accessibility, while maintaining the product experience.

Table 3 shows the recommended room sizes\* for *Room 70 Panorama* with classic tables and the content screen mounted below the main screens.

Refer to the *Additional Guidelines and Requirements for Low Ceiling Option* online for details about classic tables used with the *Room Panorama Low Ceiling option*.

**Table 3: Room 70 Panorama, content screen below the main screens**

Table size	Room size - width × length [m (inch)]					
	Minimum room		Standard room		Premium room	
Small classic, 6 persons	6.6 × 4.7 (259.5 × 185.9)		7.2 × 5.0 (283.1 × 195.7)		8.2 × 5.5 (322.8 × 216.5)	
Large classic, 6 persons	7.2 × 5.1 (283.5 × 200.8)		7.8 × 5.4 (307.1 × 212.6)		8.8 × 5.9 (346.5 × 232.3)	

\* All dimensions are after adding acoustic treatment to the walls.



# Recommended room size (page 5 of 5)

## Room height

The recommended ceiling height is 2.35 m (92.5 in.) or higher.

## Table position

Align the table to the product centerline. The distance ( $d$ ) from the back of the table to the system is:

- Small classic table: 3.0 m (118 in.)
- Large classic table: 3.4 m (134 in.)

## Avoid objects along the product centerline

For the best viewing experience, we recommend that you avoid placing objects along the center line of the product, neither on the table, on the rear wall, or otherwise in the room. Also avoid wall patterns crossing the center line, and people sitting at the center of the table.

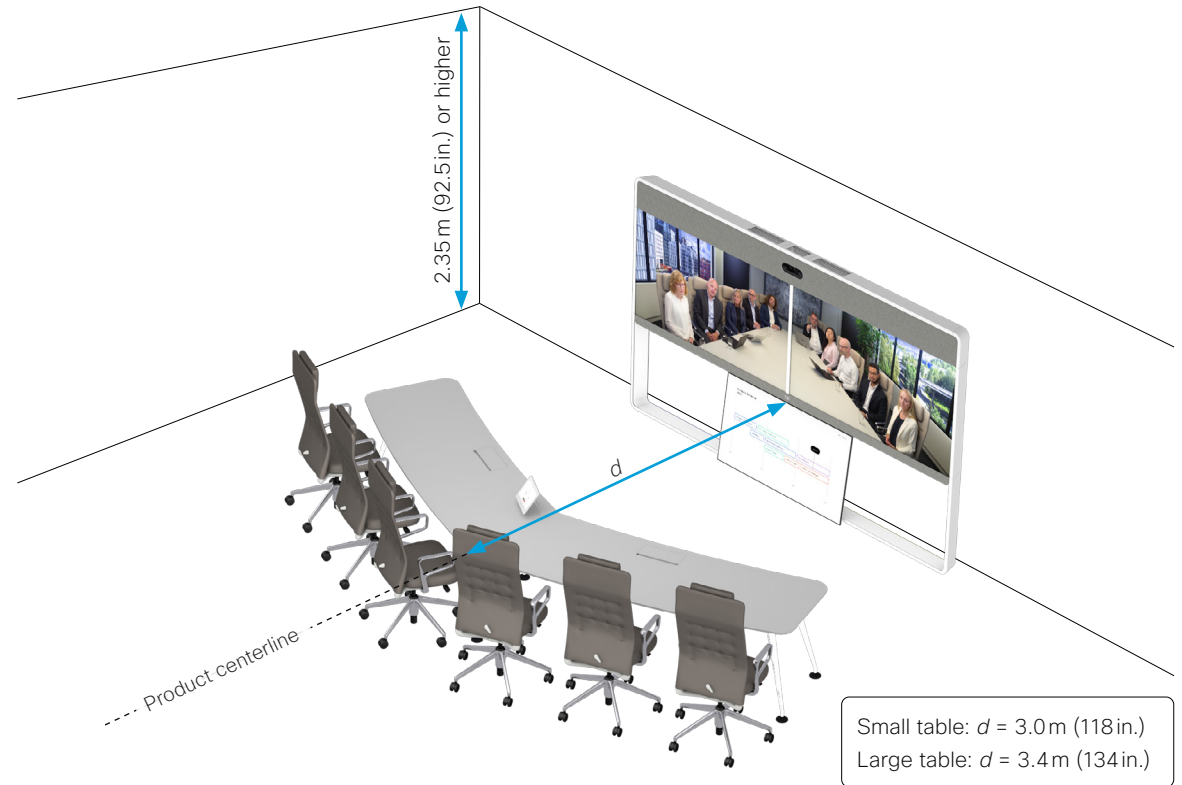

\* All dimensions are after adding acoustic treatment to the walls.

# Re-using a CTS, TX, or IX immersive room for Panorama

Many customers want to upgrade their existing CTS-3x00, TX-9x00, and IX-5x00 rooms with the new *Room Panorama* system or the smaller *Room 70 Panorama* system.

There are a few considerations to make:

- The minimum ceiling height requirement for installing a Room Panorama or Room 70 Panorama system with content screen above the main screens is 2.7 meter (106.3 in.).
- The CTS, TX and IX systems were often installed in dedicated studios, with no windows, not natural light, and purpose-built furniture to support the immersive experience.

If your immersive room is built like this, Cisco recommends you to re-purpose that space instead of using it for Room Panorama or Room 70 Panorama. The room could be built into quiet rooms, huddle spaces, or other smaller spaces that are used only for shorter meetings and where people are not staying for longer periods of time.

- The Room Panorama and Room 70 Panorama systems has been designed for normal meeting rooms.
- The systems should be installed into existing comfortable and spacious meeting rooms with windows, natural light, and a "normal" meeting room table.

A Panorama room should be the most comfortable room for users to be in for longer periods of time, to have local meetings in, and to use for video meetings.

If you still want to upgrade your existing CTS, TX or IX room to a Panorama room, here are a few recommendations:

- While the existing Immersive system normally is installed at the long wall of the room, a Panorama system should be installed at the short wall of the room.
- Look at all the different room size options in this document and find the one that match your existing space.
- Remember that you need 2.7 meter (106.3 in.) ceiling height to accommodate the content screen above the main screens. <sup>1</sup>

See examples in the "[Room dimensions for Room Panorama in an IX5000 room](#)" and "[Room dimensions for Room 70 Panorama in an IX5000 room](#)" appendices.

- If the room doesn't have the appropriate ceiling height, you can consider the Room 70 Panorama, or the Low Ceiling option of Room Panorama <sup>2</sup>, with the content screen below the main screens. This set-up requires a classic immersive table for up to 6 persons, with users sitting shoulder to shoulder, facing the system.

See an example in the "[Room dimensions for Room 70 Panorama in an IX5000 room \(page 2 of 2\)](#)" appendix.

<sup>1</sup> This is 30 cm (11.8 in.) higher than the minimum height for an IX5000 room.

<sup>2</sup> Find our *Additional Guidelines and Requirements for Low Ceiling Option* online.

## Part 2: **Tables and seating**

# Tables and seating (page 1 of 4)

## Tables

The table design plays an important role in the product experience. With Room Panorama, we wanted to create a table that works not only for video conferences, but also for local meetings.

We recommend a **tapered table shape**. The tapered table shape is ideal for both video conferencing and local meetings.

- Supports discussions around the table
- Gives all participants free view of the screens
- Free line-of-sight from the camera to each participant.
- Free line-of-flight from the loudspeaker system to each participant.
- Good conditions for tracking (face detection and audio localization).

With a straight table, people in the room naturally fan out to be able to see the screens, while the tapered table supports the natural seating positions of the people.

Refer to the "[Recommended vendors](#)" appendix to find a list of suggested table vendors.

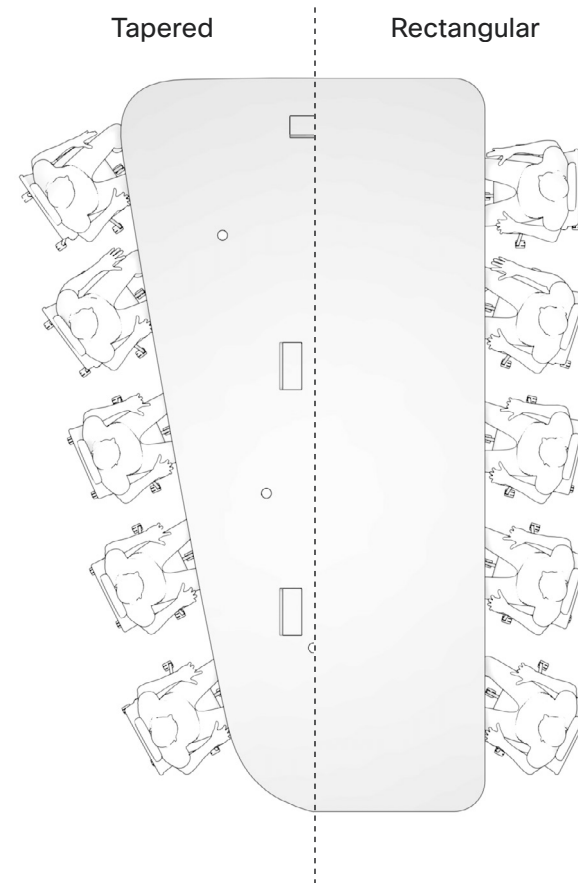

# Tables and seating (page 2 of 4)

## Tables (cont.)

### Shape and width

We recommend tapered tables in three different widths. As the table gets wider, it becomes more tapered. This is a better table arrangement for video conferences, and it gives the participants a better view to the screens.

The narrowest table is not recommended for Room Panorama; only for Room 70 Panorama.

### Capacity

For all the three table widths, the same design is used for tables for 6, 8, 10, 12, and 14 persons.

Find illustrations with dimensions in the "[Room dimensions for Room Panorama](#)" appendix.

### Color, material, and finish

The table color should give the best exposure for the people's faces. We have tested and validated this color from the Natural Color System color book for reference:

- NCS S2500-N

The table should have a smooth finish without any texture. We recommend a powdercoated finish to deliver a smooth monolithic surface finish all over the table top.

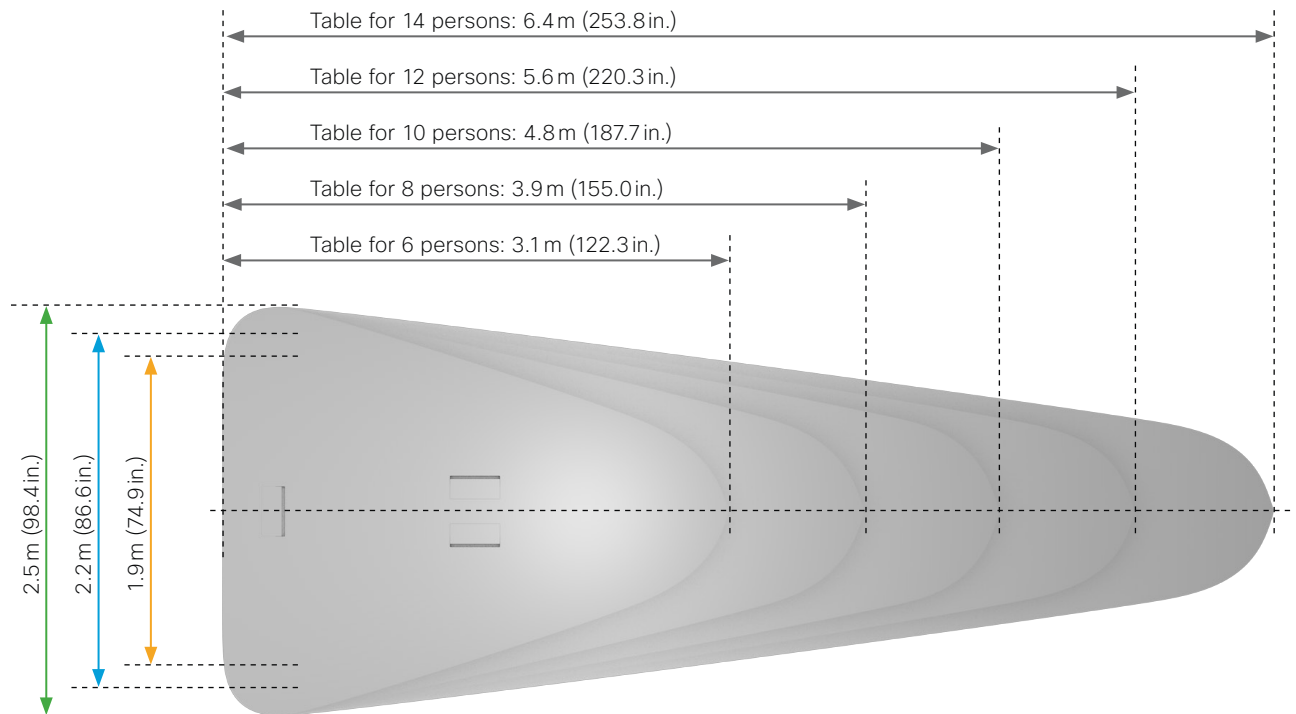
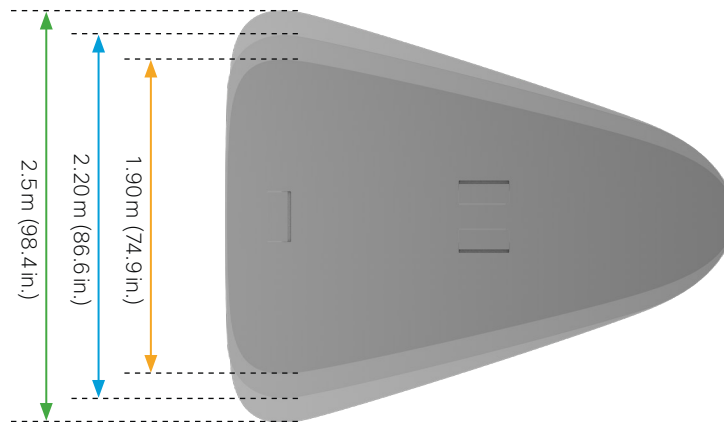

## Tables and seating (page 3 of 4)

### Seating

With our recommended table designs, we allow for spacious and comfortable seating. Each table allocates 80 cm (31.5 in.) for each person.

However, if you allow some compromise of the premium comfort, you can add two more seats at each table set up. Then there will be 70 cm (27.6 in.) for each person.

We strongly recommend that nobody sits at the end of the table.

### Ergonomics

For the best ergonomics, we recommend using chairs with headrest, swivel hinge, and coasters.

Comfortable chairs that allow meeting participants to sit back work very well with the 3-screen Panorama system, which has the content screen above the two main screens.



10 person table with premium level of comfort - 80 cm (31.5 in.) allocated for each participant.



Adding 2 persons to a 10 person table - 70 cm (27.6 in.) allocated for each participant.

## Tables and seating (page 4 of 4)

### Table and seating for a classic video conferencing room

We also provide a table design for the classic video conferencing room where users are sitting shoulder to shoulder, facing the video system. It comes in two sizes for 6 persons.

This table complements systems that have the *content screen below the main screens*, be it the Room 70 Panorama or the Low Ceiling option of Room Panorama.

Such a set-up works well for video conferences, and participants have a good view to the screens.

#### Seating

The small classic table allocates 75 cm (29.5 in.) for each person. This requires the use of the entire table width. Work with the table supplier to ensure that the table legs do not prevent comfortable seating.

The large classic table allocates 80 cm (31.5 in.) for each person, without interfering with table legs on the sides.

We strongly recommend that nobody sits at the center of the table.

For the best ergonomics, we recommend using chairs with swivel hinge and coasters.

#### Color, material, and finish

We recommend the same color and finish as we do for the tapered tables.

Small classic table for 6 persons. 75 cm (29.5 in.) allocated for each participant

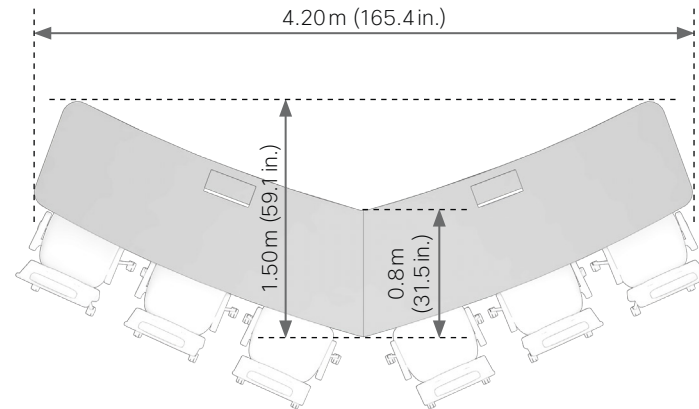

Large classic table for 6 persons. 80 cm (31.5 in.) allocated for each participant

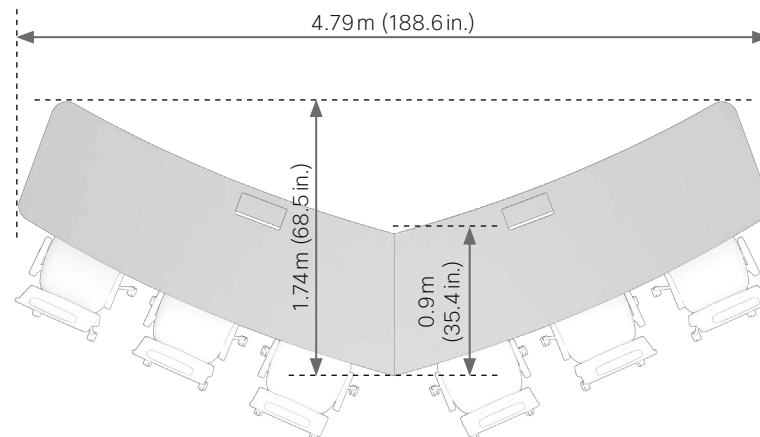

## Part 3: **Wall preparation**

(Applies only to Room Panorama; not to Room 70 Panorama)



# Preparing the wall (page 1 of 4)

Due to the size and mass of the Room Panorama system, it must be installed by qualified personnel. The installer must determine whether the wall must be reinforced prior to the installation and calculate the number and type of screws required for a safe installation.

The product is fastened to the wall through three horizontal rails. The rails must be fastened so that they can safely support the product. In total, the product weighs close to 600 kg (1320 lb). When installed correctly, the system rests on the floor.

### No obstructions



Once installed, the system covers the shaded area. There should be no obstacles in this area, not even baseboards / skirting boards.



The system will be fastened to the wall with screws in the areas marked with solid red color.

See more details in the next pages.

### Perfectly flat wall and floor

The rails must be level. If the wall is not perfectly flat, horizontally and vertically, this must be compensated for before you mount the rails.

The system has adjustable feet, which can compensate for the floor not being perfectly flat.

### Socket outlets

You must install socket outlets for power and Ethernet in the shaded area. Their exact position is shown in the "Power and Ethernet" chapter.

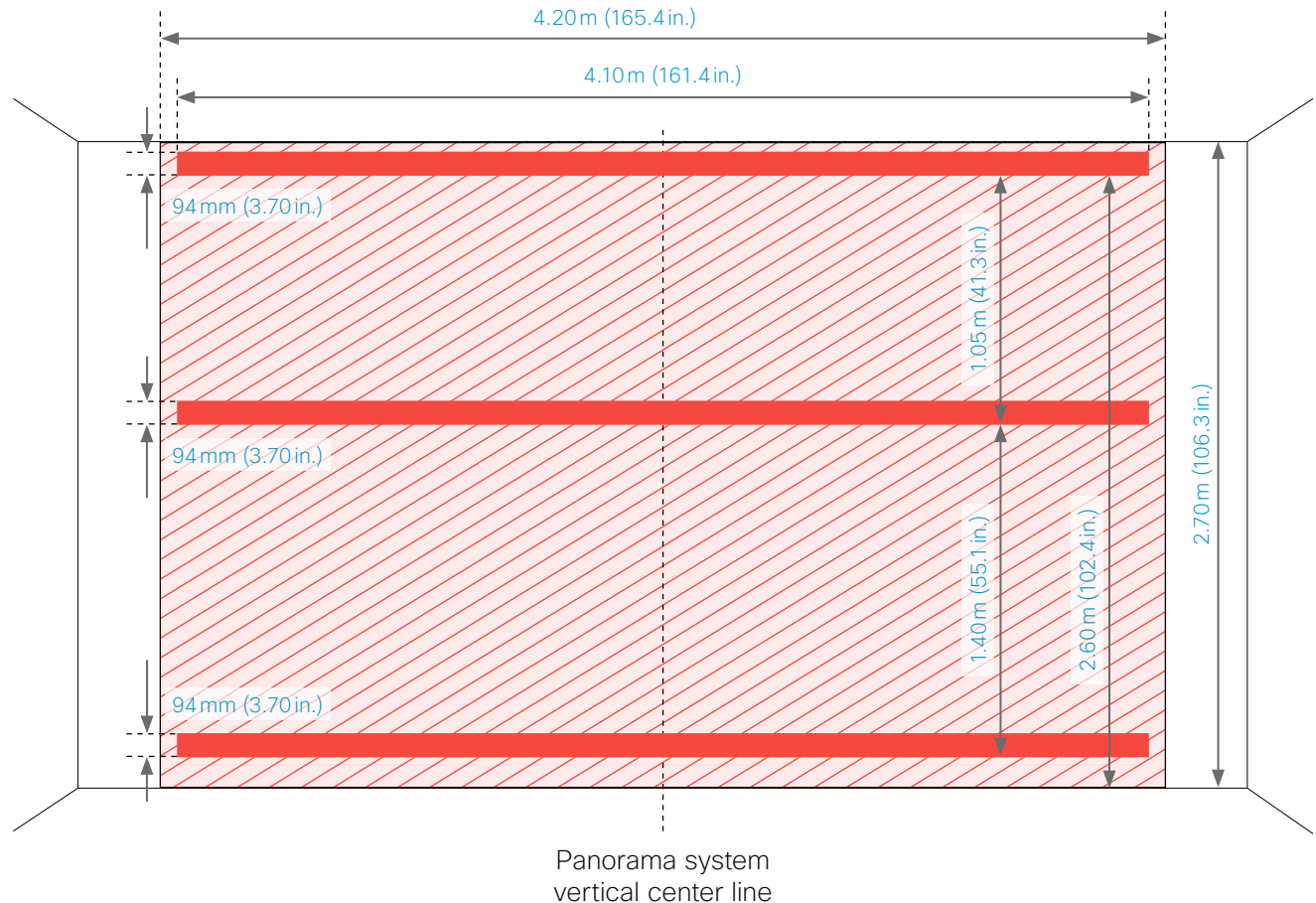

# Preparing the wall (page 2 of 4)

## Horizontal rails

Each rail is composed of three parts. All parts must be fastened securely to the wall. The number of screws depends on the type of wall.

Typical example for plaster wall:

- Upper rail: 4 + 8 + 4 screws
- Center rail: 4 + 8 + 4 screws
- Lower rail: 2 + 3 + 2 screws

You can use any of the horizontal slots.

It is important that the rails are level. If the wall is not perfectly flat, horizontally and vertically, this must be compensated for before you mount the horizontal rails.

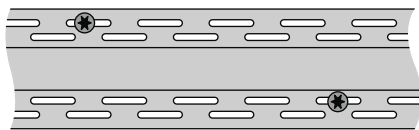

Front view of rail, fastened with screws

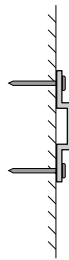

Side view of rail, fastened with screws

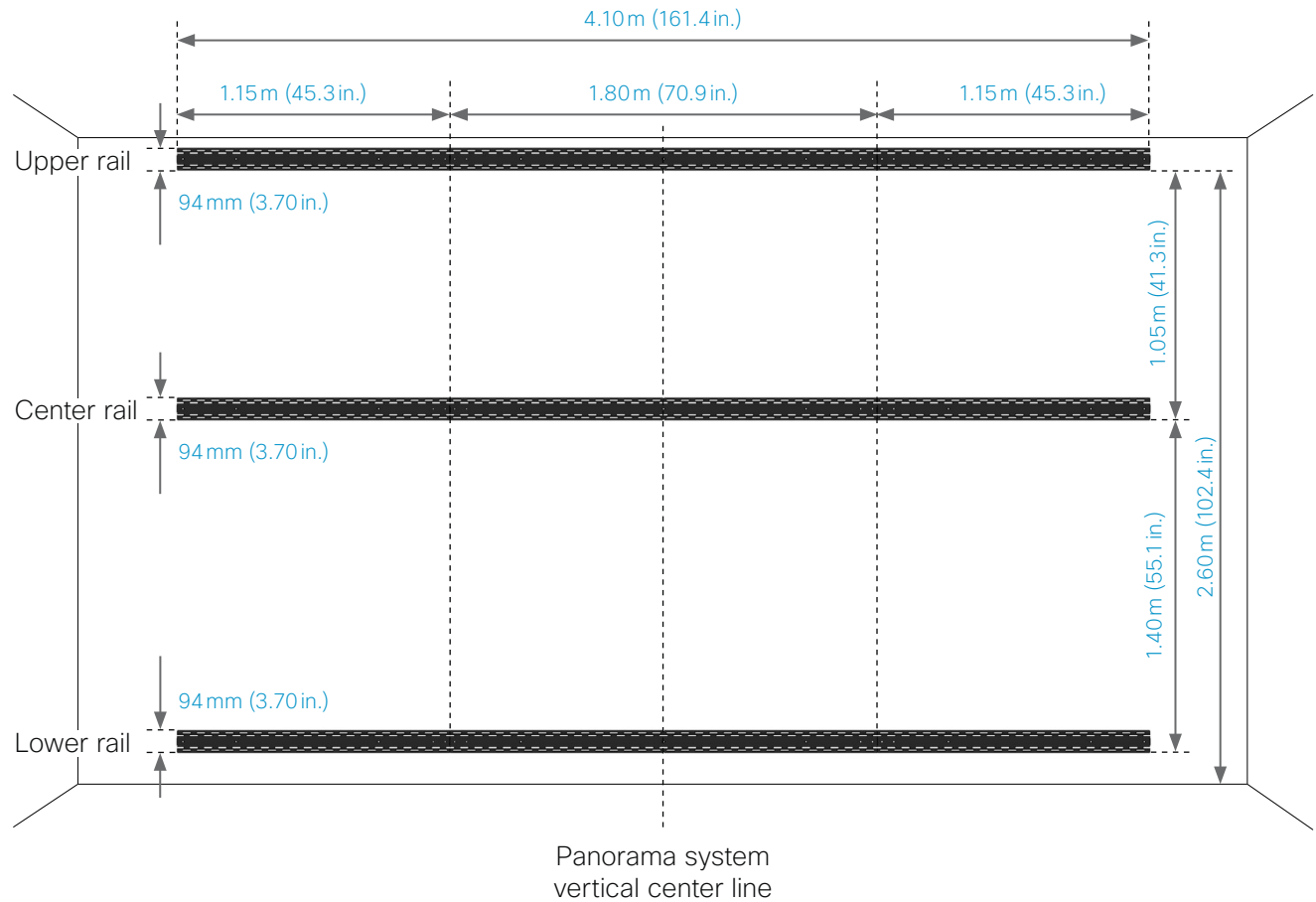

# Preparing the wall (page 3 of 4)

## Vertical risers

Seven risers hang on the rails. Their foot should be adjusted so that they rest on the floor.

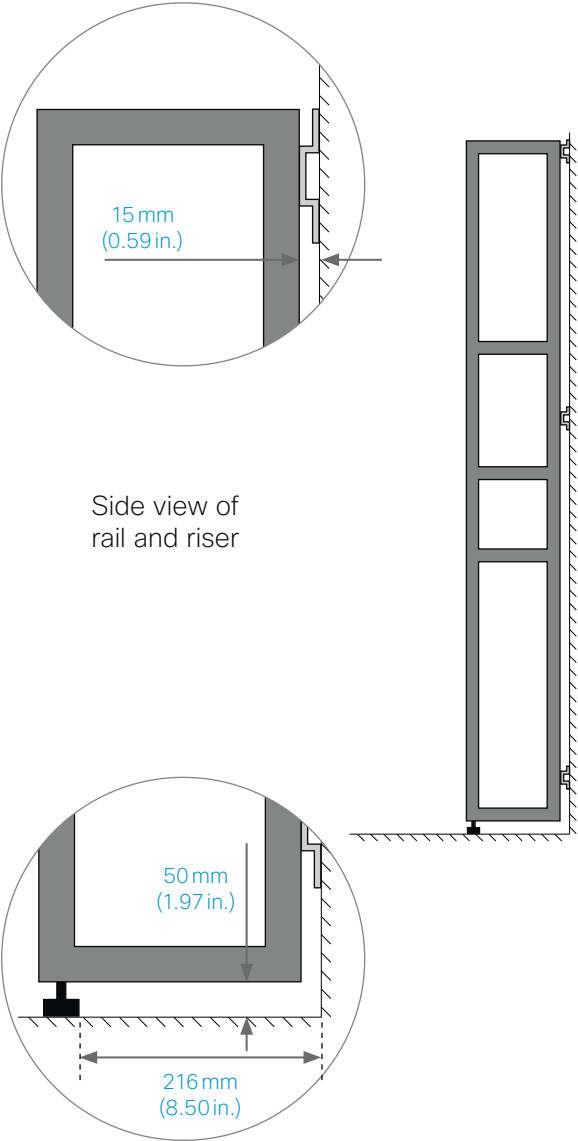

Side view of rail and riser

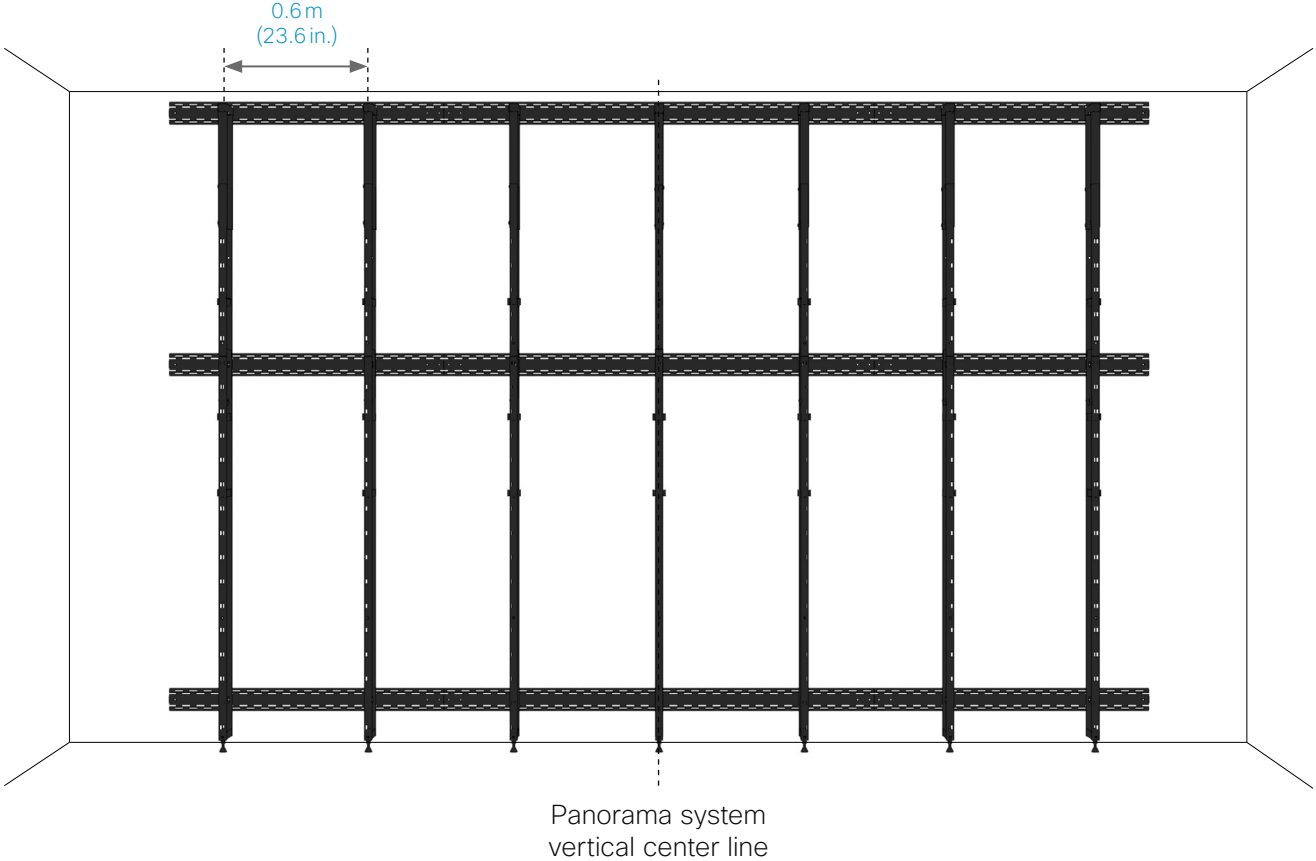

# Preparing the wall (page 4 of 4)

## Wall panels

We offer cosmetic wall panels as an option when you buy Room Panorama. Alternatively, you can design and build your own custom wall.

### Cosmetic wall panels

The cosmetic panels curve toward the wall on each side. They are adjacent to the wall all the way from bottom to top. See illustration.

You can choose between two types of finish:

- Wooden panels (light oak)
- Ready-to-paint panels

Read more in the ["Cosmetic wall panel finish"](#) appendix.

### Custom wall

The custom wall must be designed to level at the same depth as the cosmetic wall offered by us. If not, the screen brackets and the hinge mechanism to access the components behind the screens will not work as they should.

Read more in the ["Building a custom wall"](#) appendix.

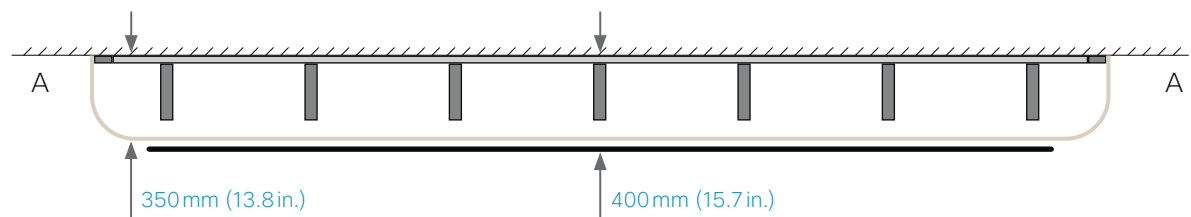

# Power and Ethernet

## Power

Wall socket outlets must be installed by a qualified electrician. Room Panorama consists of separately approved components. This requires each component to be connected directly to a wall socket outlet. You are not allowed to use a power strip (multi-socket extension cord).

### Number of outlets

In total you need 7 power outlets on the wall. For flexibility and the possibility to distribute the load, we recommend at least 4 socket outlets on each side. In addition, you need one outlet on or close to the table.

The video system's content screen has an ungrounded plug. It shall preferably be connected to one of the sockets on the right hand side. The other equipment must be grounded.

### Amount of power

The total amount of electrical power needed is (temporary figures; subject to change):

- 100V, 60Hz: 16 A / 1600W
- 240V, 50Hz: 7 A / 1600W

## LAN/Ethernet

You only need one Ethernet socket on the wall. For flexibility, you may want to have Ethernet sockets on both sides.

The Ethernet bandwidth requirement is typically 20Mbps, or higher.

## Location of sockets

Sockets for power and LAN/Ethernet must be placed within the two shaded boxes, see illustration. These areas are hidden, but easily accessible, when the Panorama system is fully mounted. You just have to pull the main screens down to get access to the sockets.

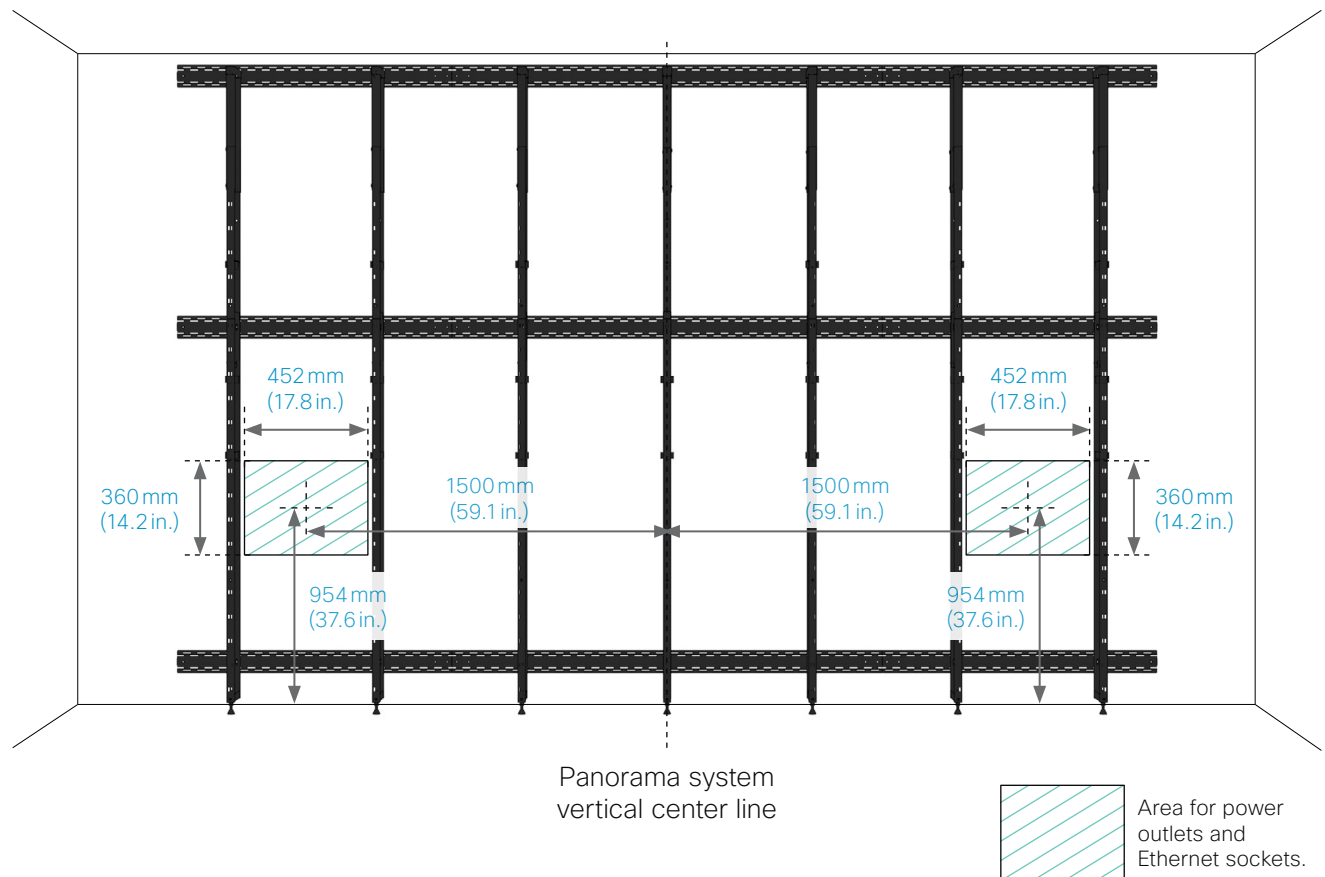

## Part 4: **Acoustic guidelines**

# Acoustic room guidelines (page 1 of 4)

These guidelines help you to get the best possible video conferencing experience and make your room a pleasant environment for both video calls and local meetings.

Understanding your meeting partners and being understood is crucial to the success of any meeting, whether it is a quarterly business review, sales pitch or a brainstorming session. Nothing does more to stop the flow of conversation than poor sound quality.

We work hard to ensure that our technology provides the highest quality audio and video in video conferencing. But every chain is only as strong as its weakest link, so let's make sure that your meeting room is on par with our technology.

The acoustic conditions of any space shape our experience in it. A conversation partner is easier to understand in a quiet, furnished room than in a busy restaurant with background noise, other guests, and hard wall and ceiling surfaces that reflect sound. The same applies to meeting rooms.

From an acoustic perspective, video conferencing rooms are more complex than ordinary meeting rooms. In a meeting room, the acoustic experience is defined by the properties of the room itself. The three most important acoustic factors are:

- Reverberation in the room ( $RT_{60}$ )
  - The time it takes for sound to decay in the room
  - Defined by the room volume and sound absorption within the room
- Noise levels (background noise)
  - Noise from technical installations, such as air-conditioning, elevators, generators, and coffee machines
  - Noise from cooling fans on equipment, such as projectors, server racks, and other equipment
- Sound insulation between the room and the surrounding environment
  - Traffic noise, maintenance work, or people walking, talking and working outside the room
  - Assure confidentiality of information shared in the room

In a video conferencing room, however, the acoustic experience is defined by the combined effect of the above-mentioned factors of your room and the other meeting participants' room.

Consequently, acoustic requirements for video conferencing are stricter than for other rooms. What makes the acoustic experience more difficult to evaluate during a video call, is that some effects of the acoustic conditions of your room may only be apparent to the remote meeting participants. Here are some examples:

- Reverberation: Longer reverberation times combined with larger distance between participants and the microphone in one room lead to reverberant sound on the remote site. This makes the participant more difficult to understand, which is fatiguing for the listener.
- Background noise: A noisy ventilation outlet above or close to a microphone makes it more difficult for remote meeting participants to understand the meeting partners.

For acoustic properties, we refer to limits satisfying requirements for *Class A* rating of rooms taken from the following:

- Norwegian Standard NS8175, Acoustic conditions in buildings – Sound classification of various types of buildings.
- ITU H.TPS-AV, Audio/video parameters for telepresence systems.

These standards are consulted because they specifically address video conferencing rooms.

*Class A* rooms correspond to *sonically exceptionally good conditions in which participants rarely are disturbed by noise*. Acoustic and architectural consultants can use these guidelines to design a meeting room or improve an existing one.

# Acoustic room guidelines (page 2 of 4)

## Reverberation time

Reverberation time ( $RT_{60}$ ) is a measure of sound decay in a space. It is the time it takes for an abruptly stopped sound to decay by 60 dB.

Sound decay influences the perception of different environments and building types. Cathedrals, bathrooms, and open outdoor spaces – they all sound distinctly different, and a good meeting room should not sound like any of them.

Reverberation is the result of sound reflections from boundaries in the room. For speech intelligibility, early reflections arriving shortly after the direct sound can be helpful. Long reverberation tails are detrimental to speech intelligibility, because words bleed into one another.

$RT_{60}$  values are expressed for one-octave bands from 125 Hz to 4 kHz. The unit is seconds.

For video conferencing rooms with a ceiling height between 2.7 m and 3.6 m, the  $RT_{60}$  should be between 0.3 s and 0.4 s. This recommendation is based on NS8175, which states a maximum  $RT_{60}$  of 0.11 times the average room height.

For the octave band centered on 125 Hz, the reverberation time may exceed the value of the higher bands by 40%. Thus the maximum permissible  $RT_{60}$  value for the 125 Hz octave band is 0.4 s to 0.55 s.

In rooms fulfilling the above requirements for  $RT_{60}$  values, the local acoustic experience is pleasant. This also allows for good sound quality during video meetings.  $RT_{60}$  values shorter than 0.3 s may make it more difficult for local participants to hear each other, especially when the speaking person is facing another direction.



# Acoustic room guidelines (page 3 of 4)

## Sound absorption

The combined sound absorptivity of surfaces in the room and the placement of absorbing materials define the reverberation time.

Sound absorptivity, the measure of how much sound energy a material absorbs rather than reflects, is given as the noise reduction coefficient *NRC* or sound absorption coefficient  $\alpha$ . The values range from 0 (a perfectly reflective material) to 1 (a perfectly absorptive material). It should be noted that single-number *NRC* or  $\alpha$  values do not consider frequencies below 250 Hz.

- Hard, rigid, sealed surfaces, such as painted concrete, marble, or glass reflect most of the incident sound energy.
- Soft, compliant, and porous materials, such as fiberglass, foam, or acoustic panels absorb incident energy.

Although they may sometimes seem at odds with the aesthetics of modern architecture, acoustic considerations are crucial for the suitability of a room as a meeting space and should be part of the design process from the start. Good design balances the aesthetic and acoustic demands to ensure a pleasant experience.

There are many different types of absorbers and techniques for using them. Transparent panels, absorbers covered with fabric or custom print, wooden panel absorbers or microperforated surfaces can be matched to suit the desired aesthetics of the workplace and create the required acoustic conditions.

Resonant absorbers are designed to dampen sound at certain frequencies, whereas porous absorbers are usually most effective at higher frequencies. In general, absorbers become more effective at lower frequencies with increasing thickness or when placed at a distance from a hard surface. Therefore, we recommend mounting absorbers such that they protrude at least 10 cm / 4 in. from the hard surface behind.

The ceiling of the room should have acoustic ceiling tiles satisfying *Sound Absorption Class A* or an *NRC* of 0.9 or above.

In addition, acoustic absorption should be placed on the walls. An area corresponding to half of the ceiling area should be covered by absorbers on adjacent walls. Avoid placing it only on opposite walls, as this leaves the other pair of opposing walls untreated. This causes flutter echo, where sound bounces between parallel surfaces. Mounting panels at an angle to the wall reduces the area of parallel surfaces and thus reduces flutter echo. Angles of 4 to 5 degrees are sufficient to break up flutter echo.

Evenly distributed absorption at the height of the participants and microphones is most effective. For spaces with glass walls, microperforated transparent absorbers help retain the aesthetics.

A carpeted floor is often thought of as sound absorption. Most carpets are not thick enough to provide substantial absorption at frequencies of interest for speech. Nonetheless, carpets and other soft surfaces dampen sound from footsteps or moving chairs, which helps reduce distracting noise.

# Acoustic room guidelines (page 4 of 4)

## Noise levels

Low noise levels are essential for a good meeting experience. Intolerably high noise levels negatively impact meeting participants' ability to follow the meeting. Further, they may lead to listening fatigue during longer meetings.

The limits are maximum permissible levels for the total noise in the room.

- Noise from technical installations, such as air-conditioning, elevators, generators, and coffee machines
- Noise from cooling fans on equipment, such as PCs, projectors, server racks, and other equipment
- Background noise from traffic

When adding equipment to the room, be aware of noise this may add.

The limits are for A-weighted, time averaged levels ( $L_{p,A,T}$ ). The averaging period corresponds to the time of use and realistic environmental conditions. This means that a meeting room used during the daytime should fulfill the requirements under conditions resembling realistic occupation of other parts of the building, traffic noise, etc.

For video conferencing rooms, we recommend a total A-weighted ambient noise level ( $L_{p,A,T}$ ) not exceeding 30dB SPL.

## Sound insulation

Sound insulation between the room and the surrounding environment is essential to:

- Guarantee the confidentiality of information shared in the meeting room
- Minimize disturbance *of* people outside the room
- Minimize disturbance *from* outside the room, such as people walking, talking and working, traffic, and maintenance work

The requirements and improvement measures for sound insulation and noise levels are closely linked. Adequate sound insulation provides the reduction of exterior noise required to meet the noise level limits.

Reducing background noise is difficult for completed rooms, as measures for fulfilling requirements are primarily structural elements, such as walls, ceilings, floors and doors with a high sound reduction index  $R_w$ . The location of the video conferencing room within the building is a major factor for the noise level from external sources, such as traffic. Where possible, a room in a quieter part of the building should be chosen.

Where purpose-built video conferencing rooms are designed, the following limits can drive the choice of materials and construction method.

Between meeting rooms used for video conferencing or confidential meetings, and neighboring spaces, the following minimum permissible levels for the sound reduction index  $R_w$  apply.

- Rooms not connected by a door:  $R_w \geq 52 \text{ dB}$
- Rooms connected by a door:  $R_w \geq 42 \text{ dB}$

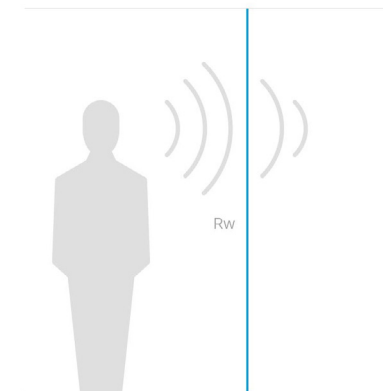

# Examples of acoustic optimization solutions

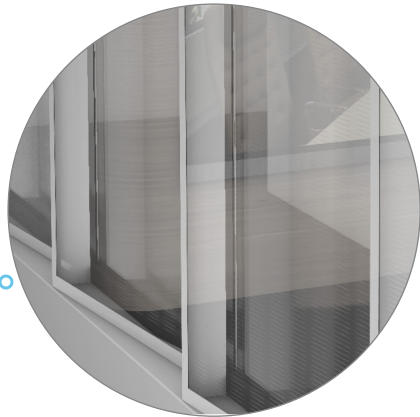

Acoustically, the room is designed as a whole. For example, DeAmp panels installed at an angle along the side wall can both absorb acoustic energy

directly and redirect reflections toward the acoustic absorbers at the rear of the room. This reduces both flutter echo and reverberation.

# Microphone guidelines (page 1 of 9)

When setting up microphones in a meeting room, it is important to consider the following factors:

- Distance between the microphone and the participant
- Volume of the room
- Reverberation time and acoustic treatment of the room
- Noise levels in the room
- Type of microphone

We recommend the Cisco Table Microphone Pro\*. The Panorama systems support up to six such microphones. They cannot be combined with other microphones.

These factors are related to each other and influence the sound quality, speech intelligibility, and overall audio experience for remote meeting participants.

For a given room, the distance between the microphone and the speaking participant determines the ratio of direct sound to reverberant sound. A microphone close to the participant receives a higher level of direct sound compared to the reverberant sound, which is preferable. A microphone further away receives more reverberant sound relative to the direct sound. This is undesirable, as it degrades sound quality, can induce listener fatigue and, ultimately, reduces speech intelligibility.

This leads to a recommended limit for the maximum tolerable distance between a participant and the closest microphone. This distance depends on four factors:

- The volume of the room
- Noise levels
- Reverberation time
- The type of microphone used

For omni-directional microphones in acoustically well-treated rooms (A-weighted noise level lower than 30 dB,  $RT_{60}$  between 0.3 s and 0.4 s), a maximum distance of 1 meter is recommended.

For directional microphones under the same conditions, the distance between the talking participant and the microphone can be up to 1.5 meter.

In acoustically poorly-treated rooms, or where these distances are exceeded, sound quality will be negatively impacted.

For these reasons, we recommend the use of Cisco table boundary microphones. These are closer to the meeting participants, who are usually seated around the table, than ceiling microphones.

The following recommendations are tailored for Panorama tables. If using a different table shape or size, it is still possible to follow these guidelines, but consider that there can be specific challenges or microphone set-ups that are not covered in depth in this document.

Refer to the "[Table microphones on non-Panorama tables](#)" section for general recommendations.

---

\* The product name changed from Cisco Microphone Array to Cisco Table Microphone Pro early 2023.

# Microphone guidelines (page 2 of 9)

## Table microphones

We recommend using one table microphone per four meeting participants. The microphone should be placed on the table with equal distance to each participant.

*Omni-directional table microphones*

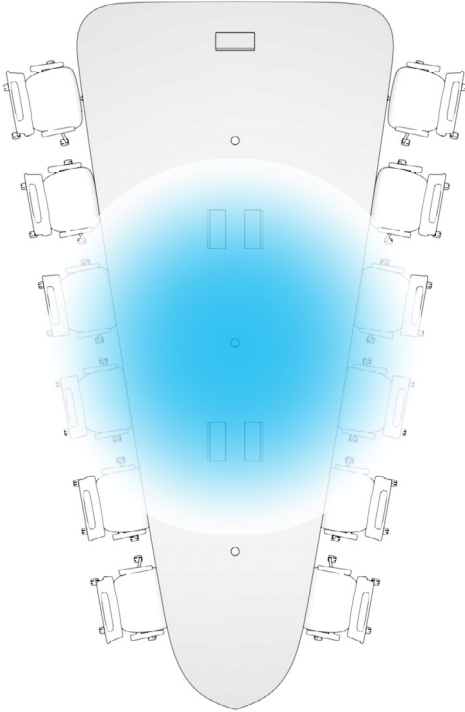

*Microphone coverage*

*Directional (cardioid) table microphones*

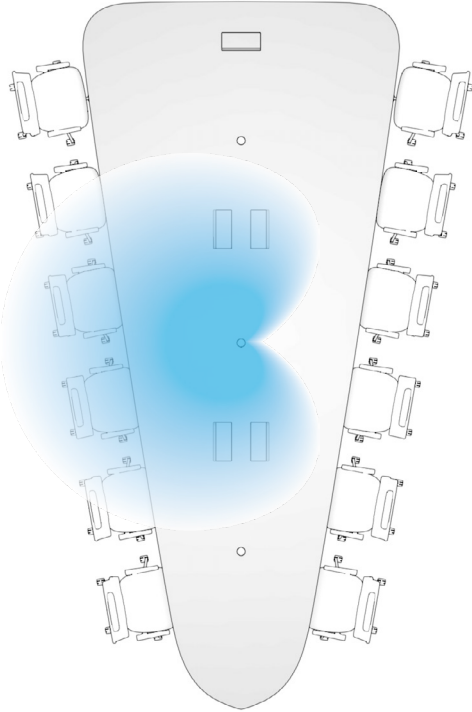

*Microphone coverage*

When using directional microphones, ensure that the sound pickup direction is facing the participants.

# Microphone guidelines (page 3 of 9)

## Table microphones (cont.)

It is important to place microphones between people, instead of directly in front of a person. This is to avoid participants' laptops interfering with the sound path from the person to the microphone. Such interference would result in muffled sound.

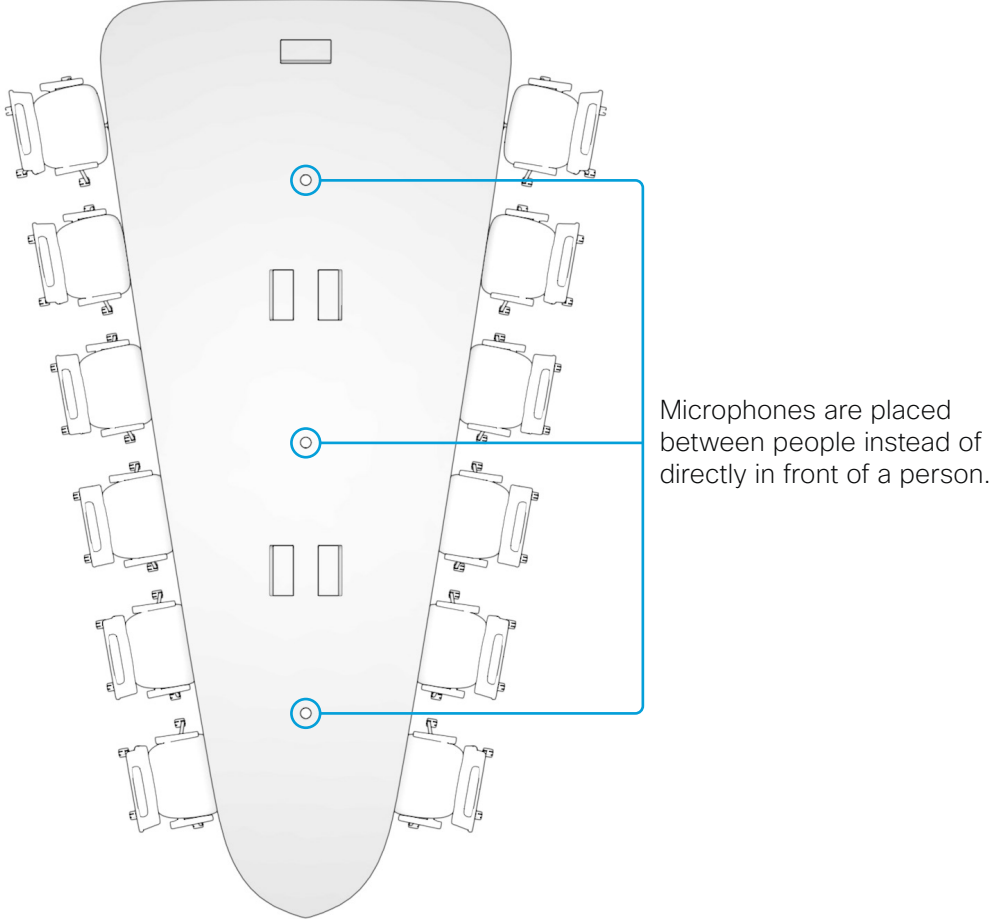

# Microphone guidelines (page 4 of 9)

## Table microphones on tapered Panorama tables

For tapered Panorama tables, we offer two microphone arrangements:

- Dual lane
- Single lane

Both arrangements provide excellent audio quality and the table layouts are uncluttered.

### Dual lane set-up

More microphones are added (in two lanes) as the table gets wider.

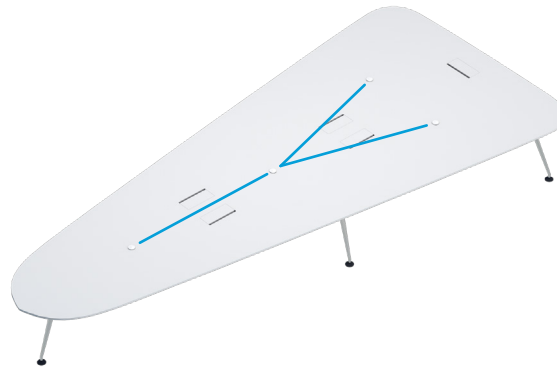

### Single lane set-up

All microphones are placed along the center line of the table.

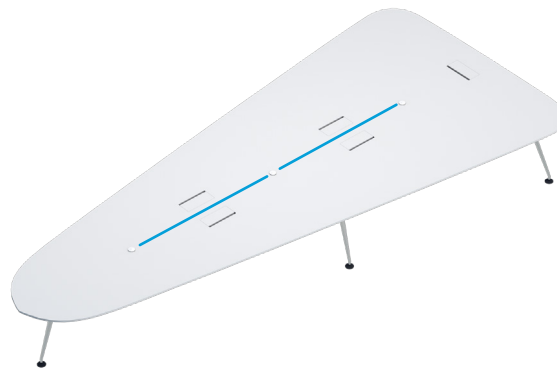

### Reaching the mute button

In a *Dual lane* arrangement, each participant can easily reach the mute button on the nearest microphone, also when sitting at the wide end of the table.

In a *Single lane* arrangement, participants at the wide end may have trouble reaching the mute button. In that case, you may consider adding other mechanisms for muting the microphones.

### Objects appearing in both camera views

The Panorama camera has two lenses. The lenses are adjusted so that objects at the rear table edge appear with natural width. As you get closer to the video system objects close to the center line will appear in both camera views.

This image distortion will be more visible for microphones that are located along the center line at the wide end of the table than at the narrow end.

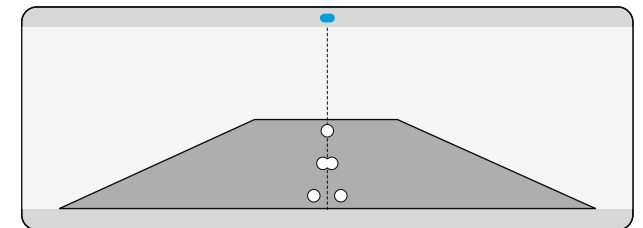

# Microphone guidelines (page 5 of 9)

## Table microphones on tapered Panorama tables (cont.)

When using multiple microphones we recommend the following distance between them to maximize coverage and speech quality:

- Recommended distance: about 1.15 m - 1.5 m (45 in. - 59 in.)

The minimum value corresponds to rooms that, from an acoustic point of view, are *less well-treated*, and the maximum value corresponds to rooms that are *well-treated*. This means that the area that a single microphone can cover is larger in acoustically well-treated rooms.

Sound reflections from table edges to the microphone create unwanted changes to its sound quality. Therefore, positioning the microphones away from table edges is important.

- Recommended distance from the front table edge: about 1 m - 1.10 m (39 in. - 43 in.)

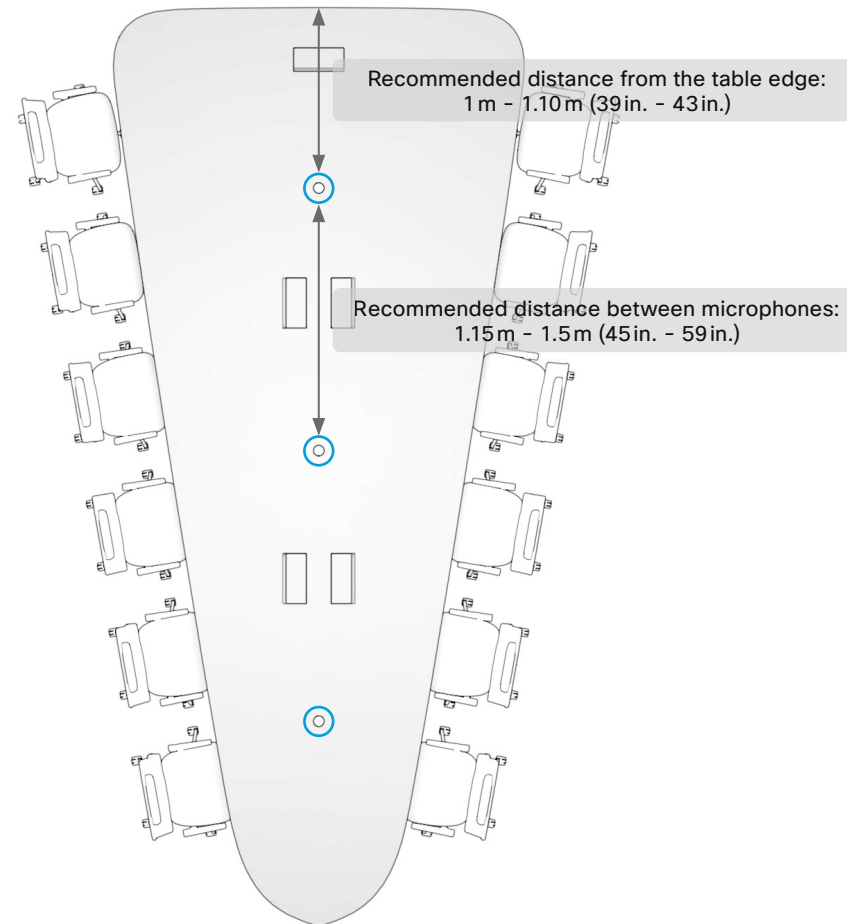



# Microphone guidelines (page 6 of 9)

## Table microphones on a classic video conferencing table

For the classic video conferencing table for six people, we recommend three microphones. The microphones are placed between the participants.

This arrangement provides excellent audio quality and the table layout is uncluttered.

### Microphone placement

The same general guidelines applies as for the tapered tables:

- Place microphones between people to avoid participants' laptops interfering with the sound path from the person to the microphone. Such interference would result in muffled sound. Each participant can easily reach the mute button on the nearest microphone.
- Recommended distance between microphones:
  - 1.25 m - 1.5 m (49 in. - 59 in.); depends on the table size and the acoustic treatment of the room.
- Sound reflections from table edges to the microphone create unwanted changes to its sound quality. Therefore, positioning the microphones away from table edges is important.

Recommended distance from table edge:

  - Small classic table: minimum 0.15 m (6 in.)
  - Large classic table: minimum 0.25 m (10 in.)

Recommended distance from the table edge:  
minimum 0.15 m (6 in.) for the small classic table and  
minimum 0.25 m (6 in.) for the large classic table

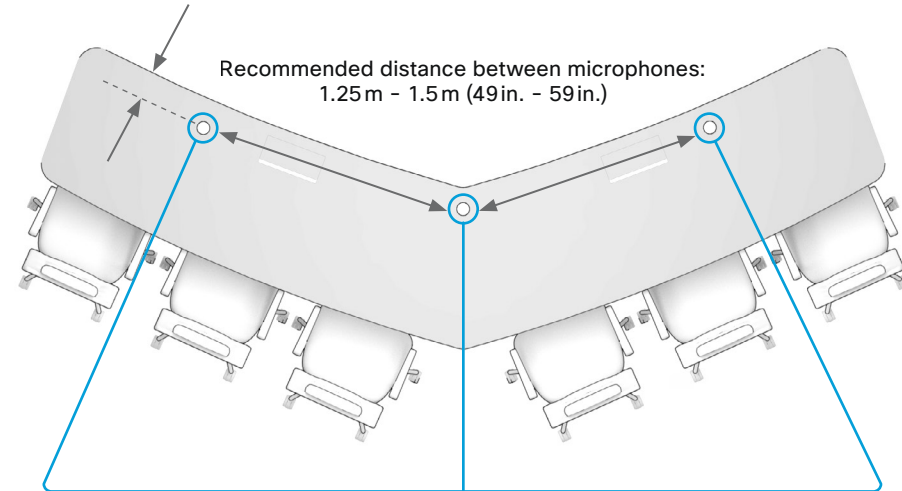

Microphones are placed between people instead of directly in front of a person.

### Objects appearing in both camera views

The Panorama camera has two lenses. The lenses are adjusted so that objects at the rear table edge appear with natural width. As you get closer to the video system objects close to the center line will appear in both camera views.

You may see some image distortion for the microphone that is placed on the center line.

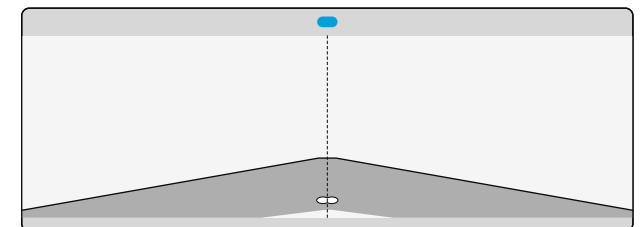

# Microphone guidelines (page 7 of 9)

## Table microphones on non-Panorama tables

If using a non-Panorama table, consider the following general guidelines for table microphone placement:

- 1 microphone will cover 4 people.
- Both flush-mounting and on-table top installations are possible, but flush-mounting the microphones in the table is the recommended approach.
- We recommend to place directional microphones about 1.5 m (59 in.) from the participants.
- We recommend to place omni-directional microphones about 1 m (39 in.) from the participants.
- When using directional microphones, make sure that the sound pickup direction is aimed toward the person.
- Where possible, the microphones should be placed between two people, instead of directly in front of a person, to minimize laptop shadowing.
- Depending on the acoustics of the room, place the microphones between 1.15 m (45 in.) and 1.5 m (59 in.) apart.
- Keep the microphones away from the edges of the table. We recommend a minimum distance of 0.15 m (6 in.).

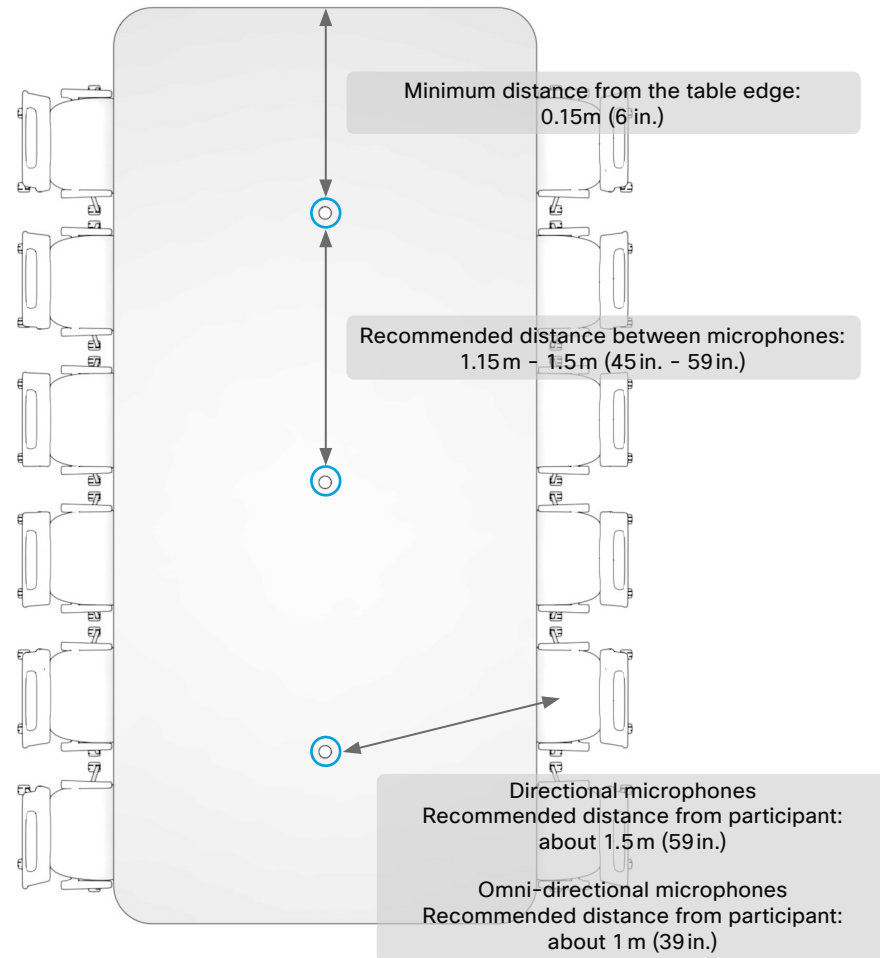

# Microphone guidelines (page 8 of 9)

## Integrating microphones to the table

The Cisco Table Microphone Pro\* can be integrated to the table in two ways:

- Flush mounted in the table **RECOMMENDED**
- On top of the table

The Panorama tables can be ordered with pre-drilled holes for the microphones.

Note that the Panorama systems support up to six Cisco Table Microphone Pro's. They cannot be combined with other microphones.

For details, refer to the [Cisco Table Microphone Pro installation guide](#).

### ***Flush mounted in the table***

Use a hole saw to make circular hole in the table. The hole must perfectly match the microphone as shown in the illustration.

We recommend flush mounting for enhanced microphone pick up quality.

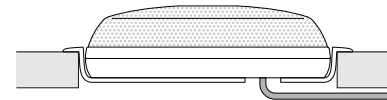

### ***Mounted on top of the table***

Drill a hole in the table for the cable routing, and then place the microphone on the table top.

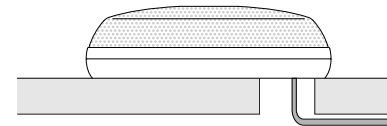

Or, route the cable along the top of the table.

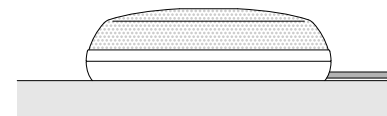

\* The product name changed from Cisco Microphone Array to Cisco Table Microphone Pro early 2023.

# Microphone guidelines (page 9 of 9)

## Ceiling microphones

Where a clean table surface is required, ceiling microphones are an alternative to table microphones.

An advantage of ceiling microphones is that they do not emphasize noise at the table surface level, such as knocking, tapping and handling objects. In addition, the participants cannot cover a ceiling microphone with notes or their laptops.

However, due to their placement, they will often be more sensitive to other sounds in the room, people moving, doors opening, as well as to ambient noise or HVAC. Because of this, it is critical to follow these acoustic guidelines when installing them.

Many modern ceiling microphones are beamformers. Beamforming microphones utilize an array of microphone elements to increase directivity of sound pick up directly towards participants, thereby reducing how much noise and reverberation the microphone picks up.

The height of the room plays an important role for whether microphones are installed flush in or suspended from the ceiling. The distance between the seated participants and the microphone impacts sound quality.

The content screen of the Room Panorama is above the main screen. The upper edge of the system is 2.70 m (106 in.) above the floor. It is important that a ceiling microphone doesn't interfere with the visibility of this screen.

## Acoustic guidelines at a glance

Quality	Value	Condition or clarification
$RT_{60}$	0.3 s - 0.4 s	One-octave bands from 125 Hz to 4 kHz
Absorption	$NRC/\alpha > 0.9$	For ceiling tiles
	Absorbers on walls corresponding to half of ceiling area	On adjacent walls
Ambient noise	$L_{p,AT} \leq 30$ dB	Measured over time of use
Sound insulation between meeting room and surrounding spaces	52 dB	Without door
	42 dB	With door
Maximum distance between table boundary microphone and participant	1 m (39.4 in.)	Omni-directional
	1.5 m (59.1 in.)	Directional
Distance between table boundary microphones	1.5 m (59.1 in.)	Acoustically well-treated rooms
	1.15 m (45.3 in.)	Acoustically less well-treated rooms

*Summary of the acoustic room and microphone guidelines*

## Part 5: **Lighting and HVAC**

# Lighting guidelines (page 1 of 3)

Lighting is essential when building great meeting rooms, supporting both local and remote telepresence meetings. Following are some general recommendations for how to create the best light conditions.

## Types of light

To make telepresence meeting participants have the best appearance, techniques from both office lighting and video production should be combined. The subject, in this case the meeting participant, should be lit with:

- **Key light** – the main light source illuminating the subject.
- **Fill light** – added to avoid dark shadows over participants eyes, and a lack of it may cause the whites of the eyes to be lost along with any possibility of eye contact.
- **Backlight** – makes the subjects stand out from the background and gives depth to the scene.

## Improving the perception of depth

To make meeting participants stand out from the background and promote a perception of depth, backlight is used. By placing light sources close to surrounding, bright colored walls, light will reflect back into the room. This will cast light on the back of meeting participants, illuminating their contour, thus causing a backlight effect.

To provide additional separation of the subject from background, the background itself should be lighted with less intensity than the subjects in the foreground.

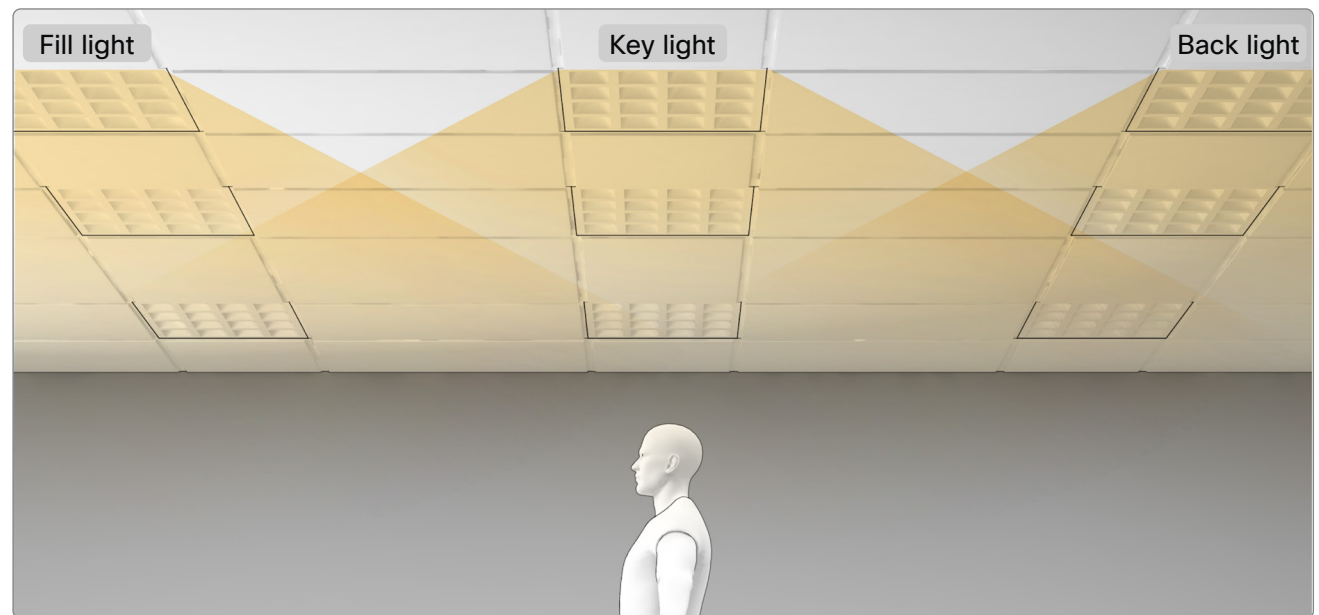

Example from PowerBalance by Signify

## Lighting guidelines (page 2 of 3)

### **Glare**

A glare-free luminary with a beam angle of 90° or wider is optimal for video, as it will serve as both key light, as well as fill light. Some luminaries are made with less spread to avoid glare, thus focusing the effect on the work area rather than people's faces. Such luminaries are therefore not ideal for video capture as they create less fill light.

Be aware that luminaries that are placed too close to the screens may cause reflections (glare). The content screen (upper screen) is exposed the most to such reflections.

### **Light intensity**

The recommended light intensity for faces is 400–500 lux, measured vertically. The general norm for illumination in meeting rooms is 500 lux. This is not sufficient for achieving high quality video capture.

We recommend 700–900 lux on horizontal work surfaces.

### **Even light**

The lighting in the room should be even, with little variance between light and dark areas. This is typically measured as uniformity. The higher the uniformity number, the more even the lighting.

We recommend a uniformity number ( $E_{min}/E_m$ ) higher than 0.8 on work surfaces.

### **Flicker**

The camera system will automatically adjust to avoid flicker and stroboscopic effects caused by temporal artifacts in the room lighting. However, by utilizing a lighting system with minimal flicker, ideally with a switching frequency that is a multiple of 60 Hz, the camera can run at optimal settings, resulting in the highest quality camera capture.



# Lighting guidelines (page 3 of 3)

## ***Color temperature***

A light color temperature of 4000K often works well, but there are different user preferences around the globe.

For optimal video capture, avoid blending light sources with different color temperatures. Some luminaires provide tunable white. This solution is ideal, as it allows for both matching preferences, as well as continuously adjusting the color temperature during the day to match the color of daylight.

## ***Color rendering***

In order to render skin tones and room interior with correct colors, it is important to have a color-rendering index (CRI) of 85 or better.

## ***Don't mix different lighting technologies***

Be careful if mixing different lighting technologies such as fluorescent lights and LED as their color profiles might differ. This might reduce the cameras ability to represent colors correctly.

## ***Lighting control***

Lighting control of the room should be automated.

Select a light control system that can be controlled by the Room Panorama system. By integrating these systems, the Room Panorama can automatically trigger the ideal lighting scene for the meeting.

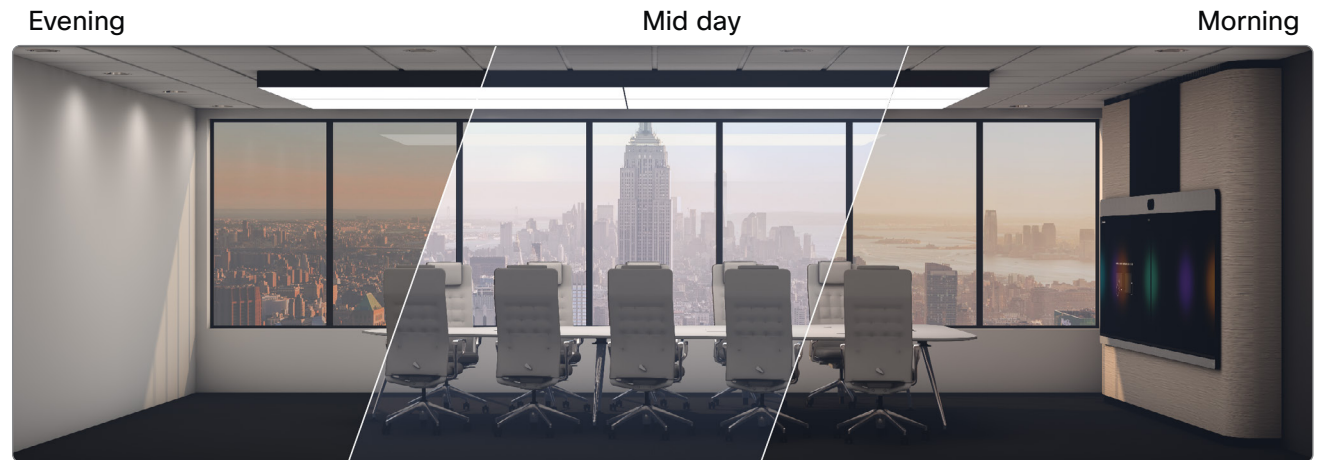

*Example from OneSpace by Signify*

# Heating, ventilation and air-conditioning

The Room Panorama system uses approximately 1200W in normal operation.

The Room 70 Panorama system uses approximately 700W in normal operation.

Ask your HVAC installer for advice about the type and size of installations you need in your room.

## ***Avoid structural vibrations***

The Panorama system should not be installed in rooms where structural vibrations are present—typically in rooms close to large machinery installations.

If the vibrations are severe, they are likely to cause camera shake and thus affect the user experience.

## Part 6: **Appendices**

# Room dimensions for Room Panorama (page 1 of 8)

**Number of persons:**

- 2 x 7 seats → 80 cm [31.5 in.] per seat
- 2 x 8 seats → 70 cm [27.6 in.] per seat

**Recommended table width:**

- 2.5 m [98.4 in.]

**Minimum room height:**

- 2.70 m [106.3 in.]\*

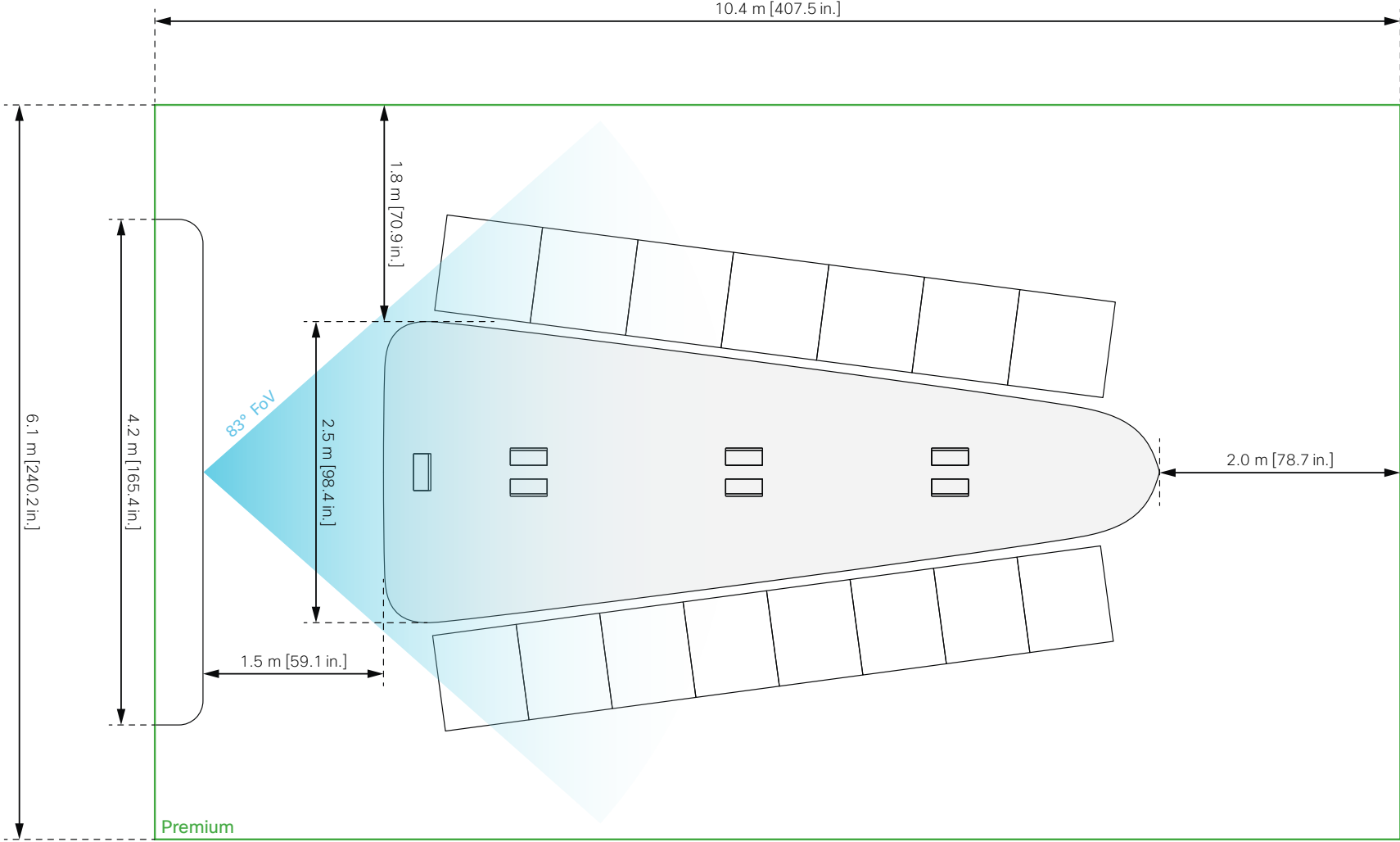

\* If your room does not have the correct ceiling height, refer to our *Additional Guidelines and Requirements for Low Ceiling Option* online.

# Room dimensions for Room Panorama (page 2 of 8)

**Number of persons:**

- 2 x 6 seats → 80 cm [31.5 in.] per seat
- 2 x 7 seats → 70 cm [27.6 in.] per seat

**Recommended table width:**

- 2.5 m [98.4 in.]

**Minimum room height:**

- 2.70 m [106.3 in.]\*

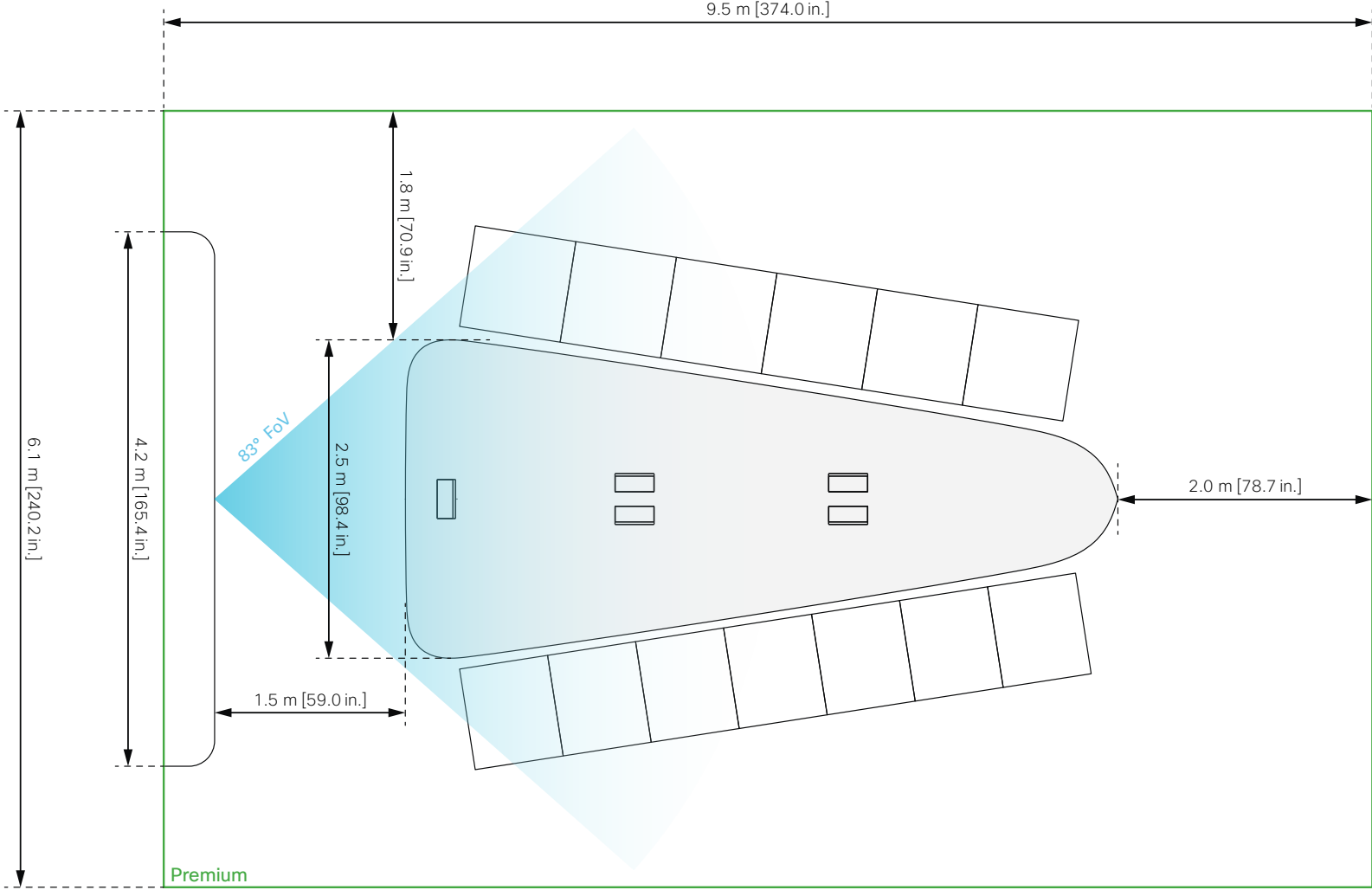

\* If your room does not have the correct ceiling height, refer to our *Additional Guidelines and Requirements for Low Ceiling Option* online.

# Room dimensions for Room Panorama (page 3 of 8)

**Number of persons:**

- 2 x 5 seats → 80 cm [31.5 in.] per seat
- 2 x 6 seats → 70 cm [27.6 in.] per seat

**Recommended table width:**

- 2.2 m [86.6 in.] (next page)
- 2.5 m [98.4 in.] (this page)

**Minimum room height:**

- 2.70 m [106.3 in.]\*

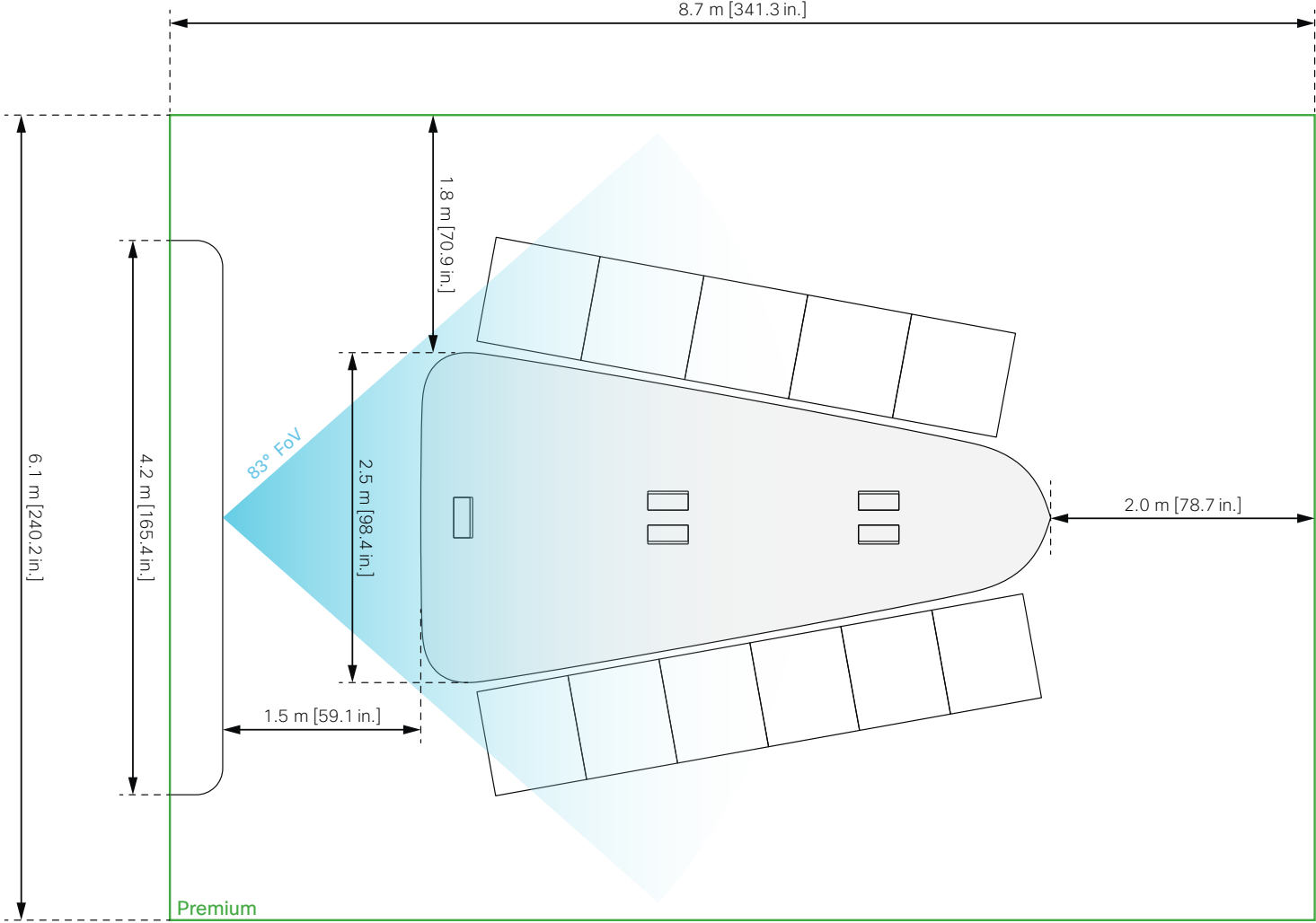

\* If your room does not have the correct ceiling height, refer to our *Additional Guidelines and Requirements for Low Ceiling Option* online.

# Room dimensions for Room Panorama (page 4 of 8)

**Number of persons:**

- 2 x 5 seats → 80 cm [31.5 in.] per seat
- 2 x 6 seats → 70 cm [27.6 in.] per seat

**Recommended table width:**

- 2.2 m [86.6 in.] (this page)
- 2.5 m [98.4 in.] (previous page)

**Minimum room height:**

- 2.70 m [106.3 in.]\*

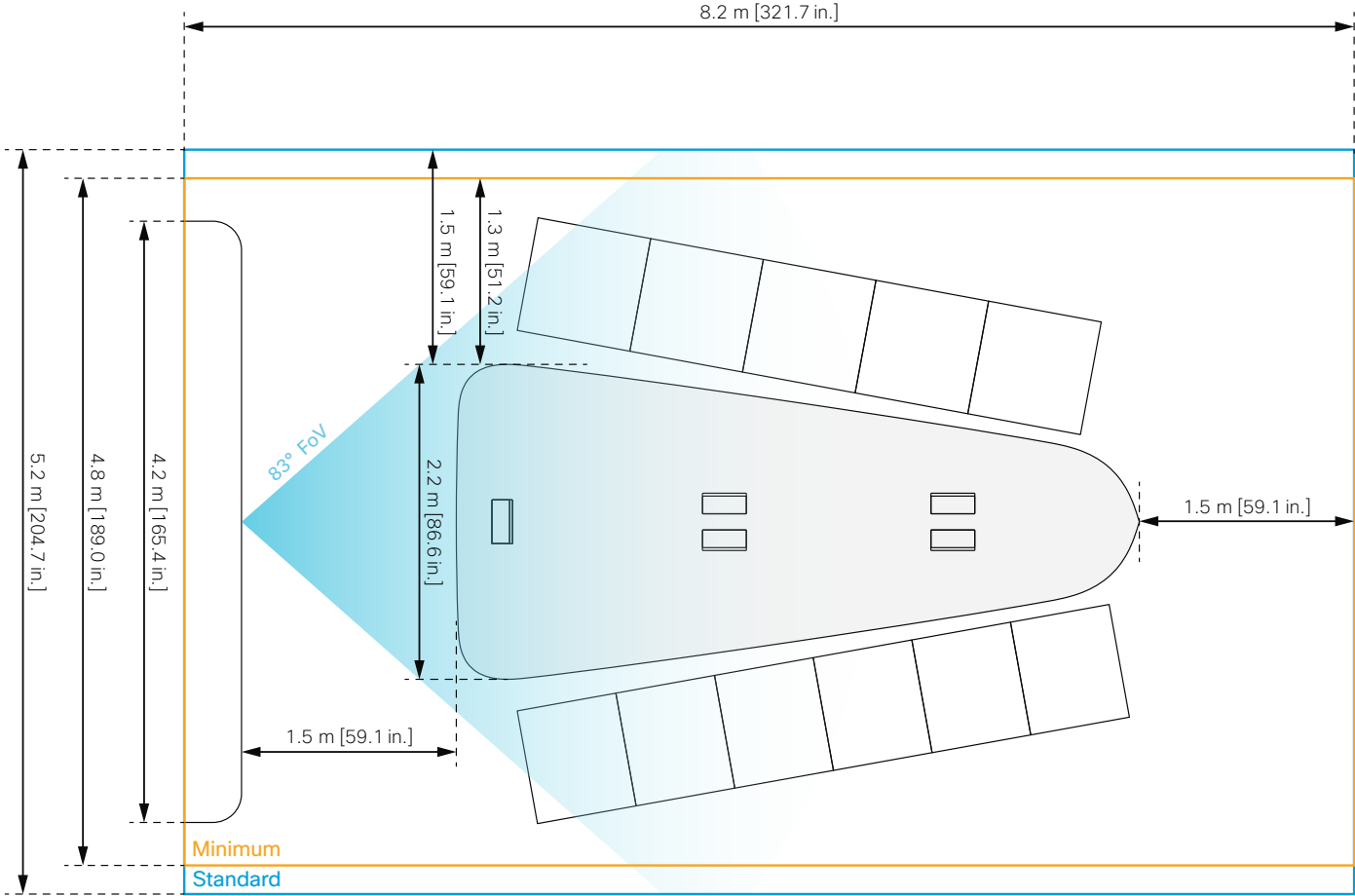

\* If your room does not have the correct ceiling height, refer to our *Additional Guidelines and Requirements for Low Ceiling Option* online.

# Room dimensions for Room Panorama (page 5 of 8)

## Number of persons:

- 2 × 4 seats → 80 cm [31.5 in.] per seat
- 2 × 5 seats → 70 cm [27.6 in.] per seat

## Recommended table width:

- 2.2 m [86.6 in.] (next page)
- 2.5 m [98.4 in.] (this page)

## Minimum room height:

- 2.70 m [106.3 in.]\*

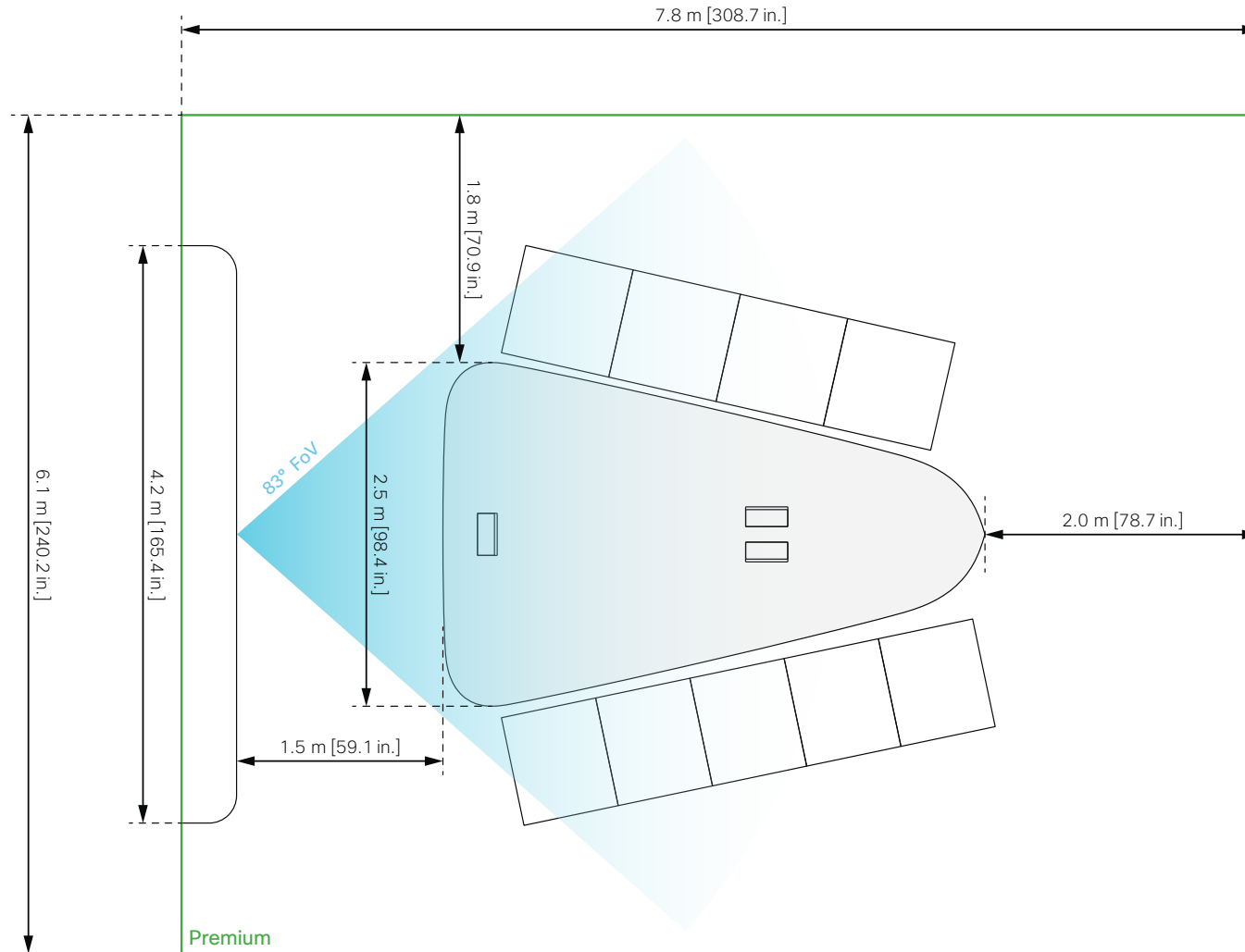

\* If your room does not have the correct ceiling height, refer to our *Additional Guidelines and Requirements for Low Ceiling Option* online.



# Room dimensions for Room Panorama (page 6 of 8)

**Number of persons:**

- 2 x 4 seats → 80 cm [31.5 in.] per seat
- 2 x 5 seats → 70 cm [27.6 in.] per seat

**Recommended table width:**

- 2.2 m [86.6 in.] (this page)
- 2.5 m [98.4 in.] (previous page)

**Minimum room height:**

- 2.70 m [106.3 in.]\*

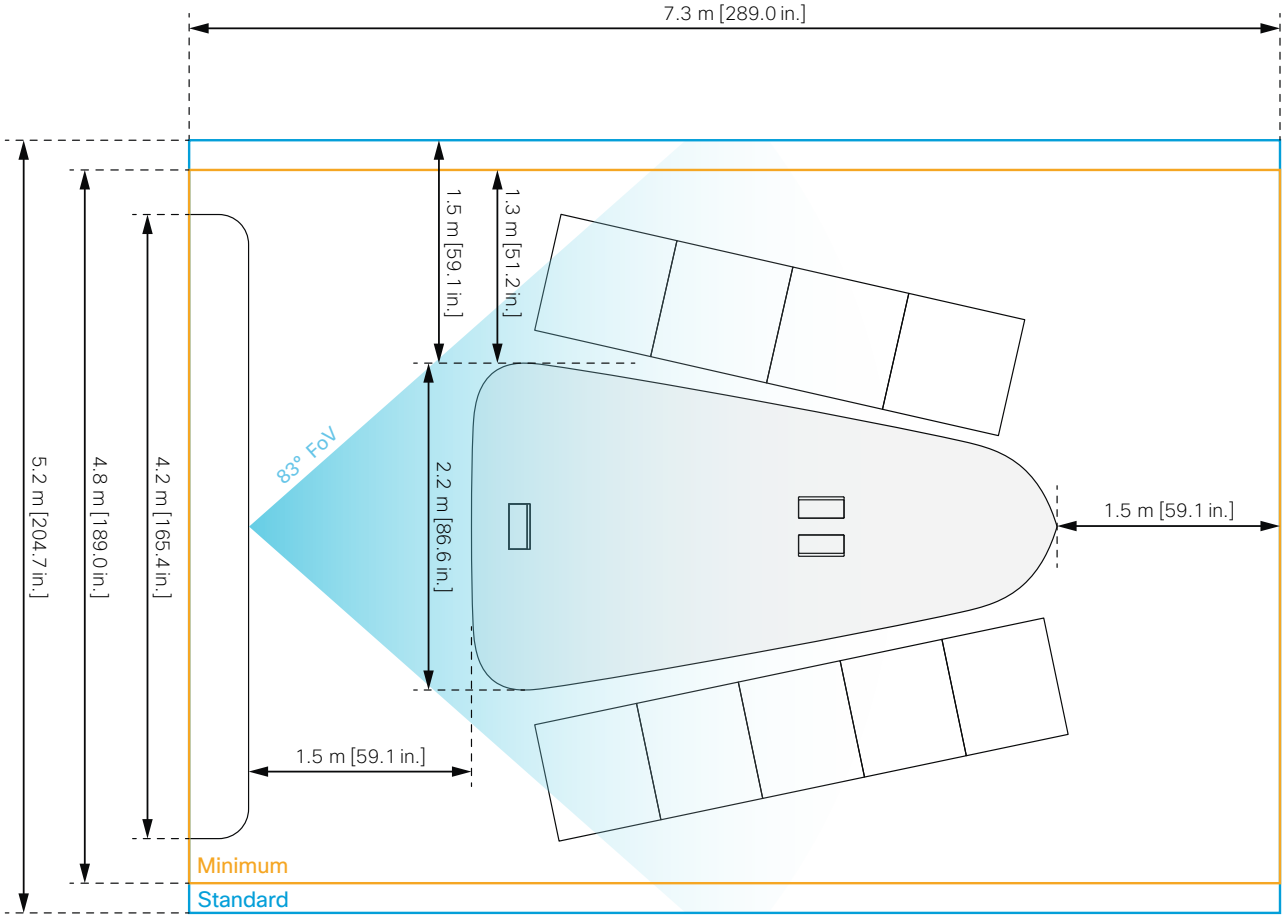

\* If your room does not have the correct ceiling height, refer to our *Additional Guidelines and Requirements for Low Ceiling Option* online.

# Room dimensions for Room Panorama (page 7 of 8)

**Number of persons:**

- 2 x 3 seats → 80 cm [31.5 in.] per seat
- 2 x 4 seats → 70 cm [27.6 in.] per seat

**Recommended table width:**

- 2.2 m [86.6 in.] (next page)
- 2.5 m [98.4 in.] (this page)

**Minimum room height:**

- 2.70 m [106.3 in.]\*

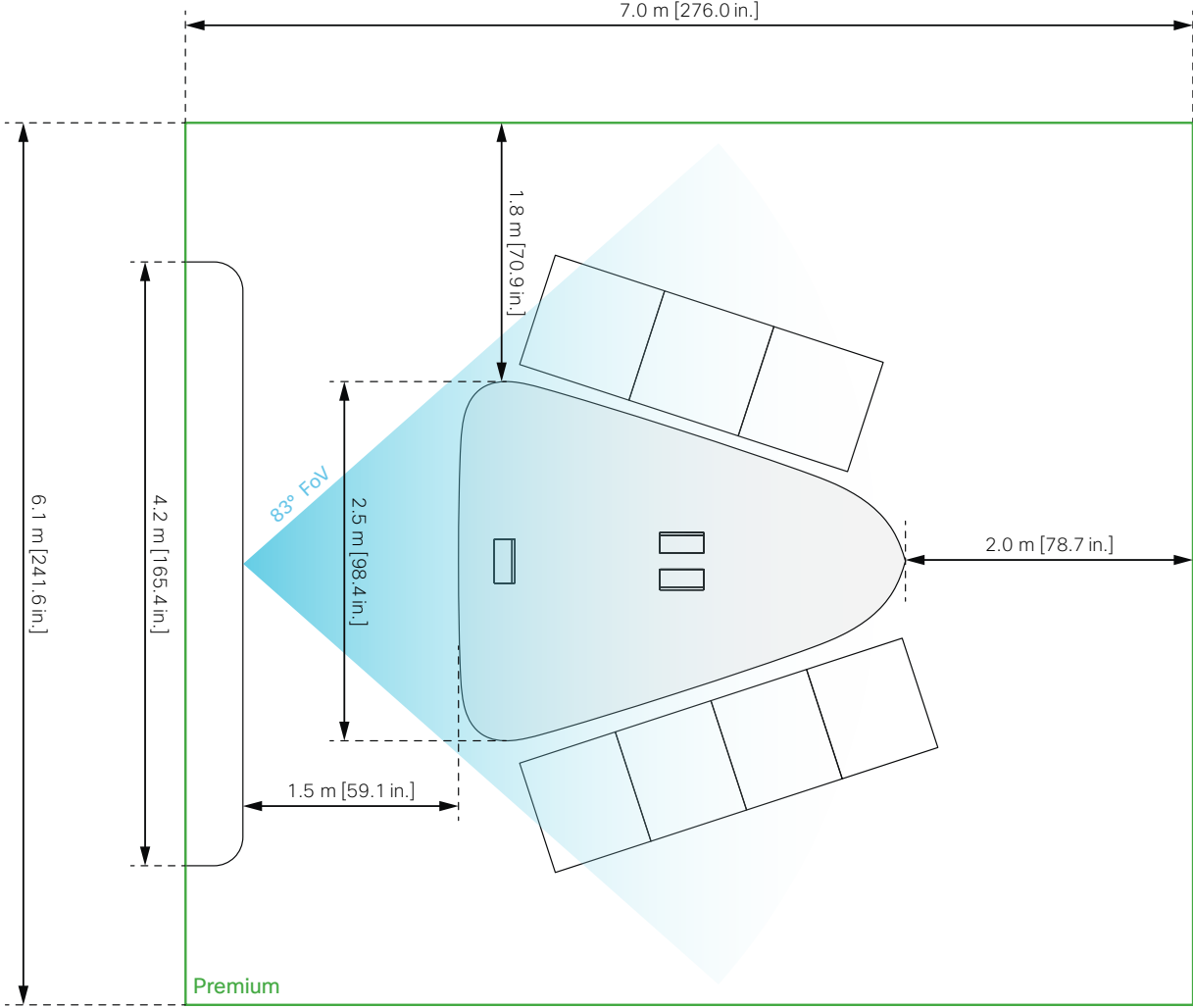

\* If your room does not have the correct ceiling height, refer to our *Additional Guidelines and Requirements for Low Ceiling Option* online.

# Room dimensions for Room Panorama (page 8 of 8)

**Number of persons:**

- 2 x 3 seats → 80 cm [31.5 in.] per seat
- 2 x 4 seats → 70 cm [27.6 in.] per seat

**Recommended table width:**

- 2.2 m [86.6 in.] (this page)
- 2.5 m [98.4 in.] (previous page)

**Minimum room height:**

- 2.70 m [106.3 in.]\*

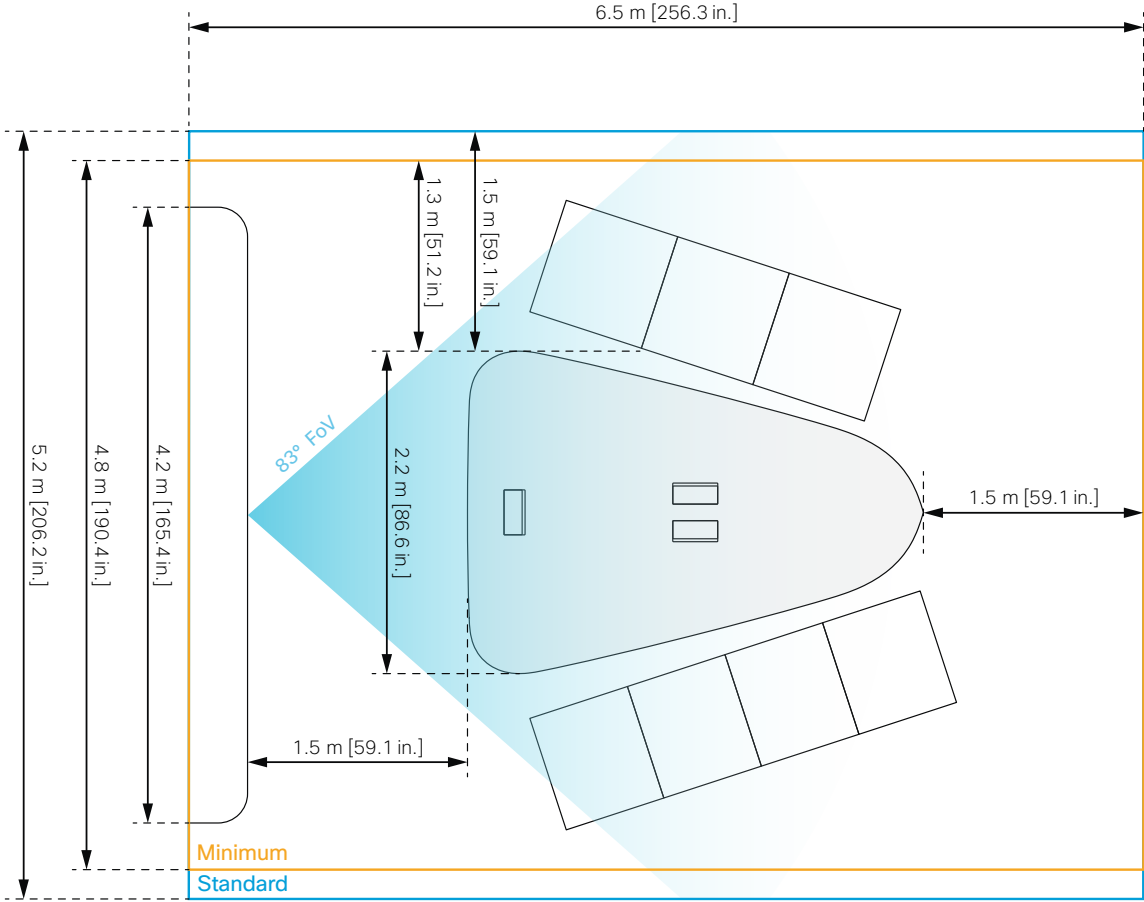

\* If your room does not have the correct ceiling height, refer to our *Additional Guidelines and Requirements for Low Ceiling Option* online.

# Room dimensions for Room Panorama in an IX5000 room

**Number of persons:**

- 2 x 3 seats → 80 cm (31.5 in.) per seat
- 2 x 4 seats → 70 cm (27.6 in.) per seat

**Recommended table width:**

- 2.2 m [86.6 in.]

**Minimum room height:**

- 2.70 m [106.3 in.]\*

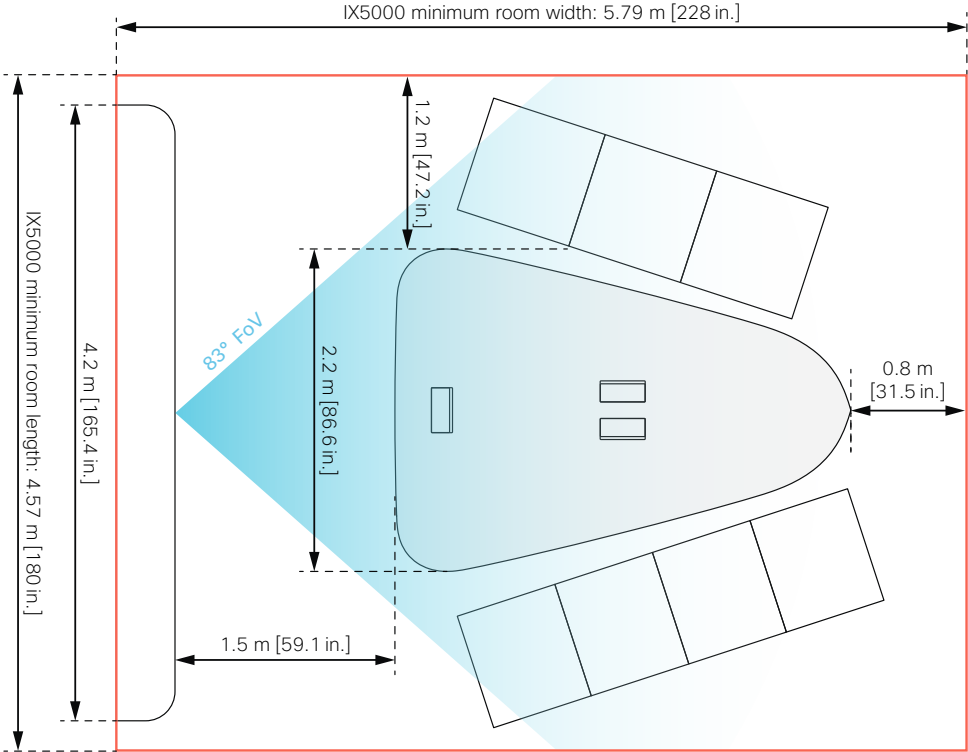

\* If your room does not have the correct ceiling height, refer to our *Additional Guidelines and Requirements for Low Ceiling Option* online.

# Room dimensions for Room 70 Panorama (page 1 of 12)

Content screen above the main screens

**Number of persons:**

- 2 × 7 seats → 80 cm [31.5 in.] per seat
- 2 × 8 seats → 70 cm [27.6 in.] per seat

**Recommended table width:**

- 2.5 m [98.4 in.]

**Minimum room height:**

- 2.70 m [106.3 in.]

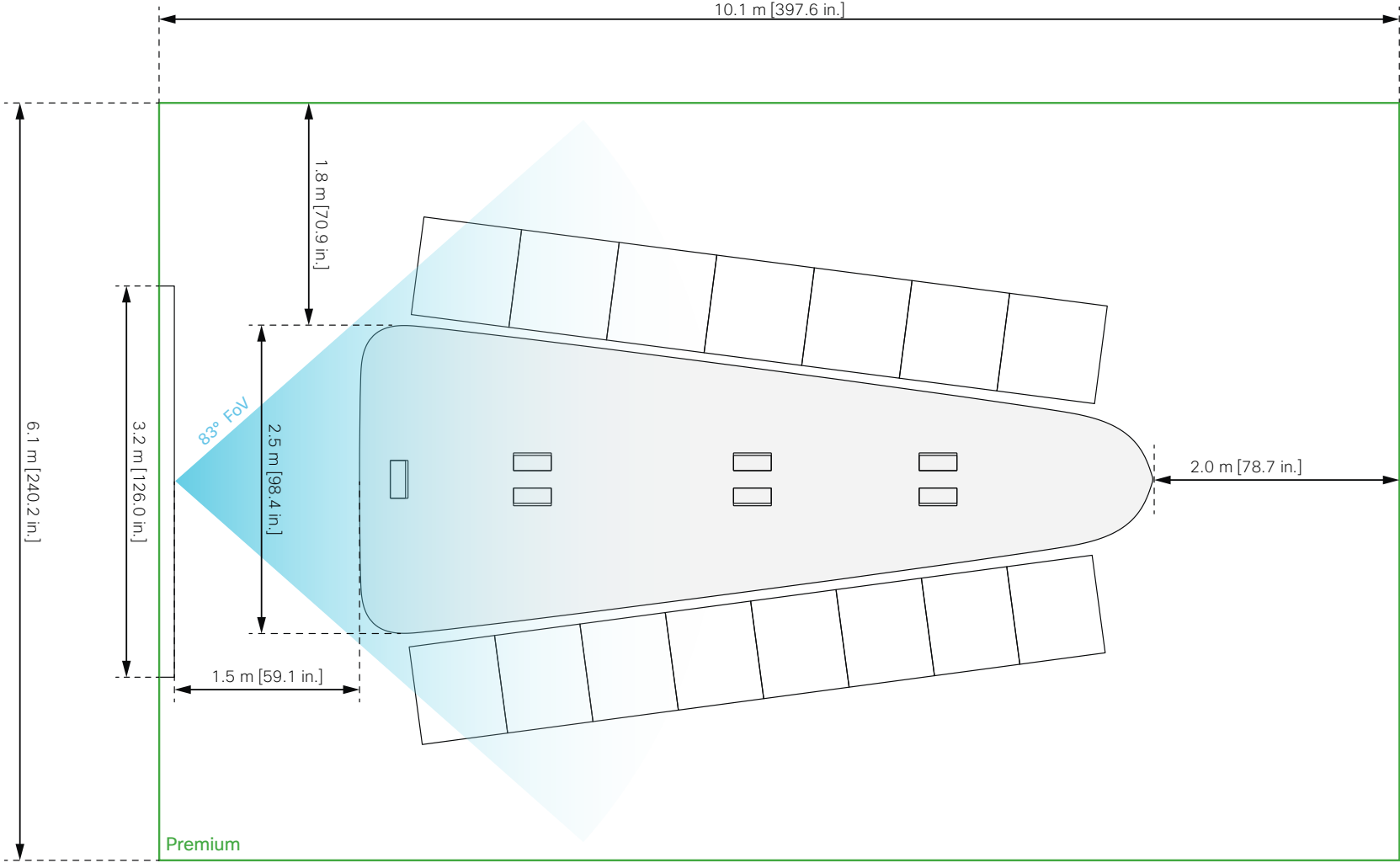

# Room dimensions for Room 70 Panorama (page 2 of 12)

Content screen above the main screens

## Number of persons:

- 2 × 6 seats → 80 cm [31.5 in.] per seat
- 2 × 7 seats → 70 cm [27.6 in.] per seat

## Recommended table width:

- 2.5 m [98.4 in.]

## Minimum room height:

- 2.70 m [106.3 in.]

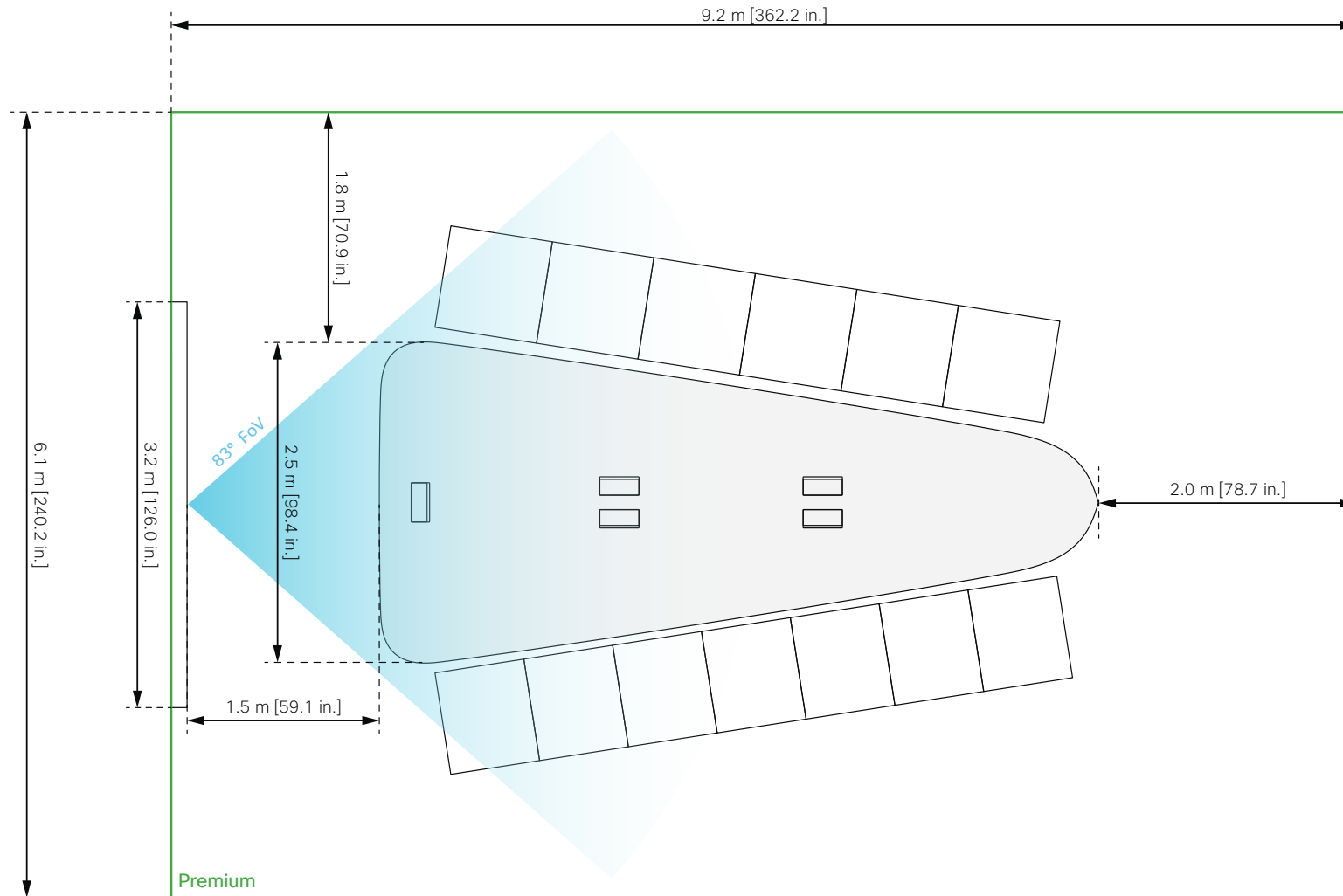

# Room dimensions for Room 70 Panorama (page 3 of 12)

Content screen above the main screens

## Number of persons:

- 2 × 5 seats → 80 cm [31.5 in.] per seat
- 2 × 6 seats → 70 cm [27.6 in.] per seat

## Recommended table width:

- 2.2 m [86.6 in.] (next page)
- 2.5 m [98.4 in.] (this page)

## Minimum room height:

- 2.70 m [106.3 in.]

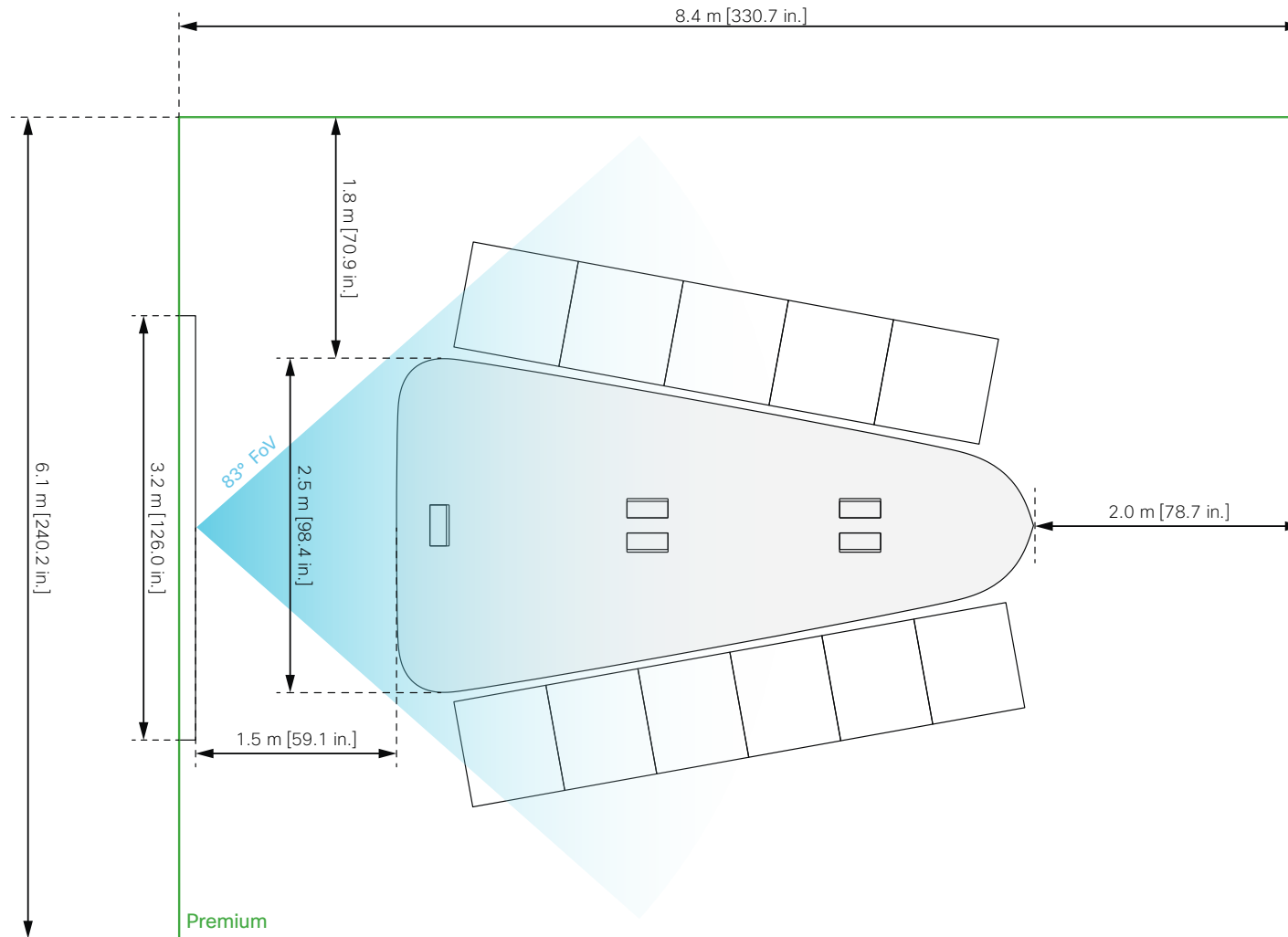

# Room dimensions for Room 70 Panorama (page 4 of 12)

Content screen above the main screens

## Number of persons:

- 2 × 5 seats → 80 cm [31.5 in.] per seat
- 2 × 6 seats → 70 cm [27.6 in.] per seat

## Recommended table width:

- 2.2 m [86.6 in.] (this page)
- 2.5 m [98.4 in.] (previous page)

## Minimum room height:

- 2.70 m [106.3 in.]

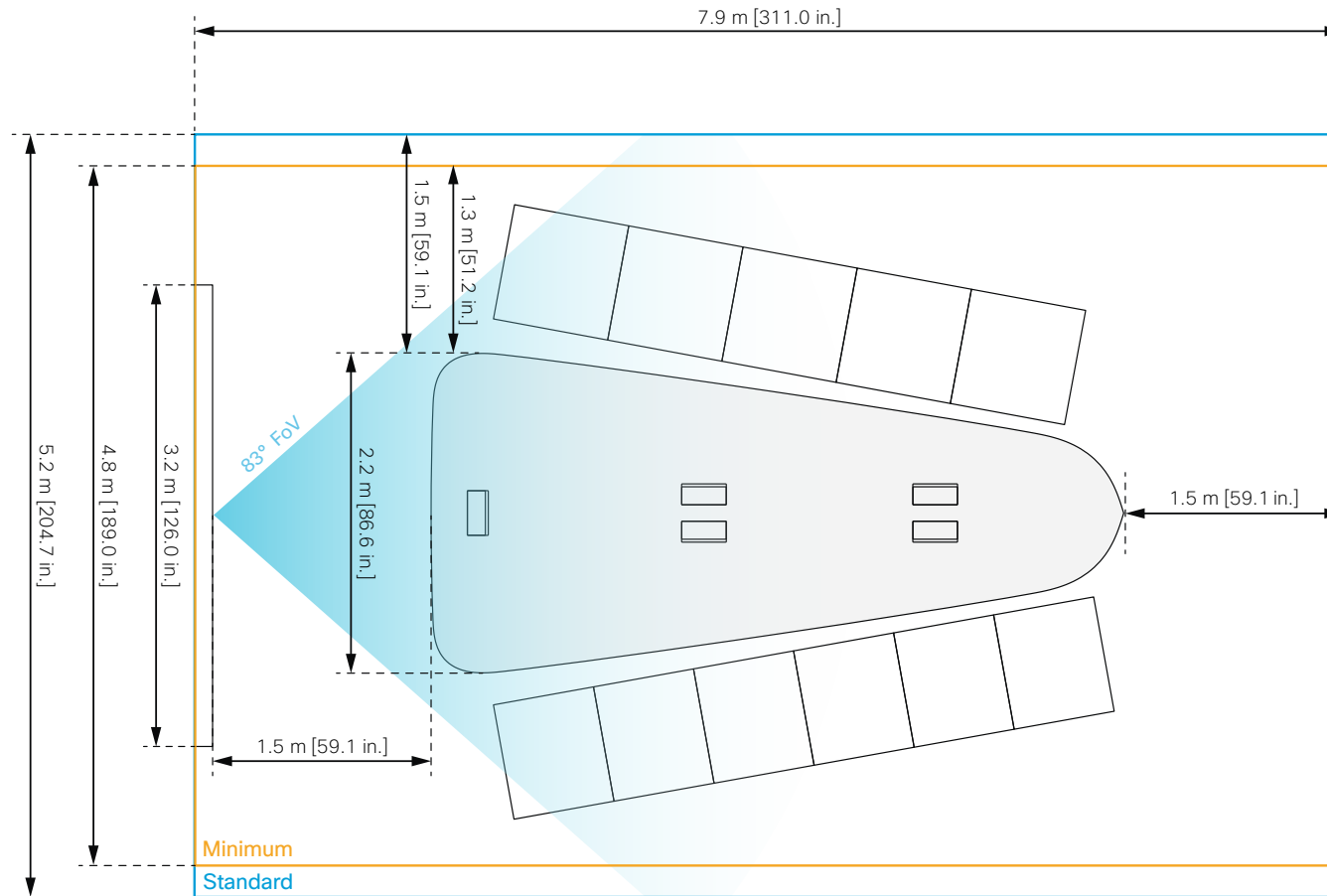



# Room dimensions for Room 70 Panorama (page 5 of 12)

Content screen above the main screens

## Number of persons:

- 2 × 4 seats → 80 cm [31.5 in.] per seat
- 2 × 5 seats → 70 cm [27.6 in.] per seat

## Recommended table width:

- 1.9 m [74.8 in.] (in two pages)
- 2.2 m [86.6 in.] (next page)
- 2.5 m [98.4 in.] (this page)

## Minimum room height:

- 2.70 m [106.3 in.]

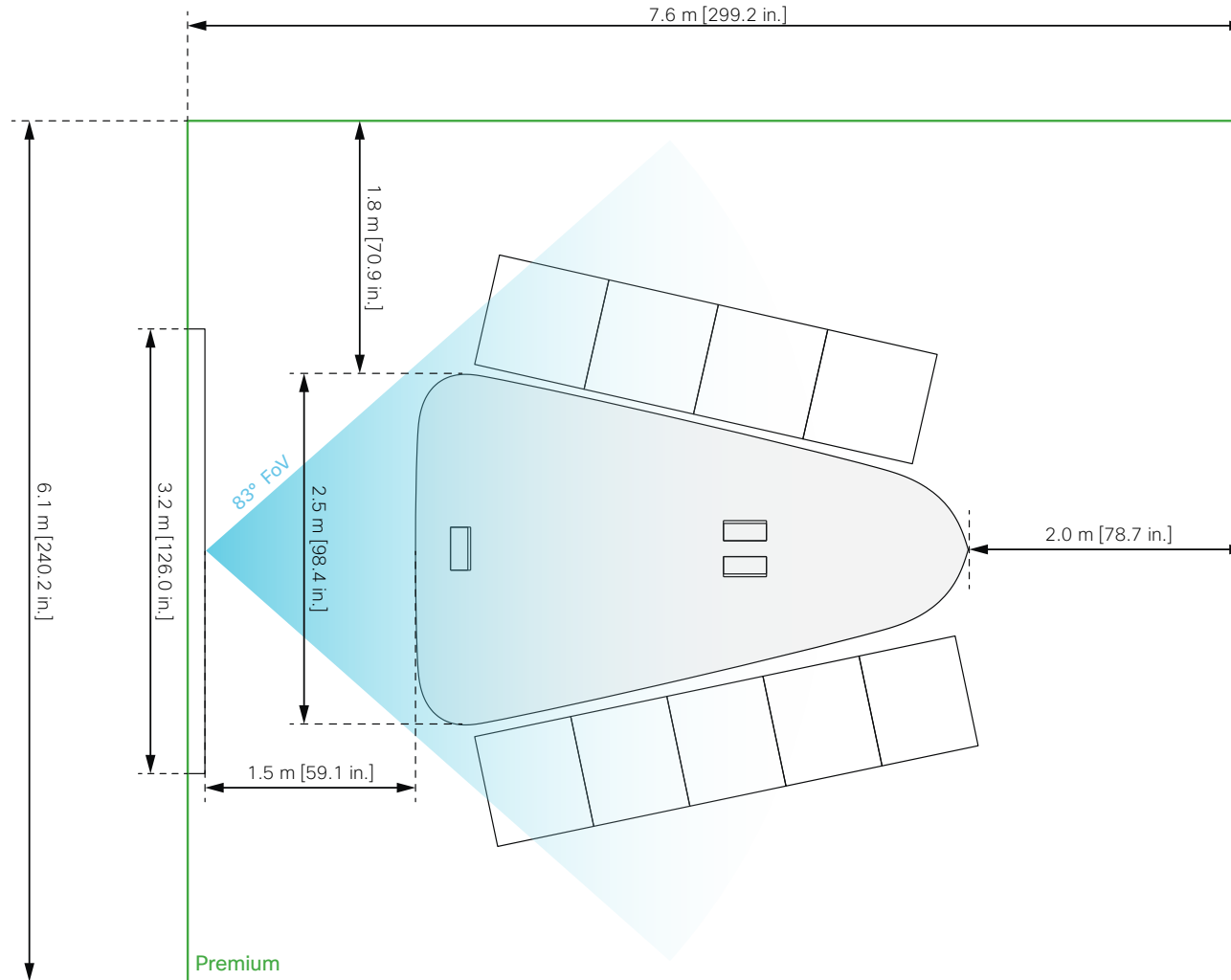

# Room dimensions for Room 70 Panorama (page 6 of 12)

Content screen above the main screens

**Number of persons:**

- 2 x 4 seats → 80 cm [31.5 in.] per seat
- 2 x 5 seats → 70 cm [27.6 in.] per seat

**Recommended table width:**

- 1.9 m [74.8 in.] (next page)
- 2.2 m [86.6 in.] (this page)
- 2.5 m [98.4 in.] (previous page)

**Minimum room height:**

- 2.70 m [106.3 in.]

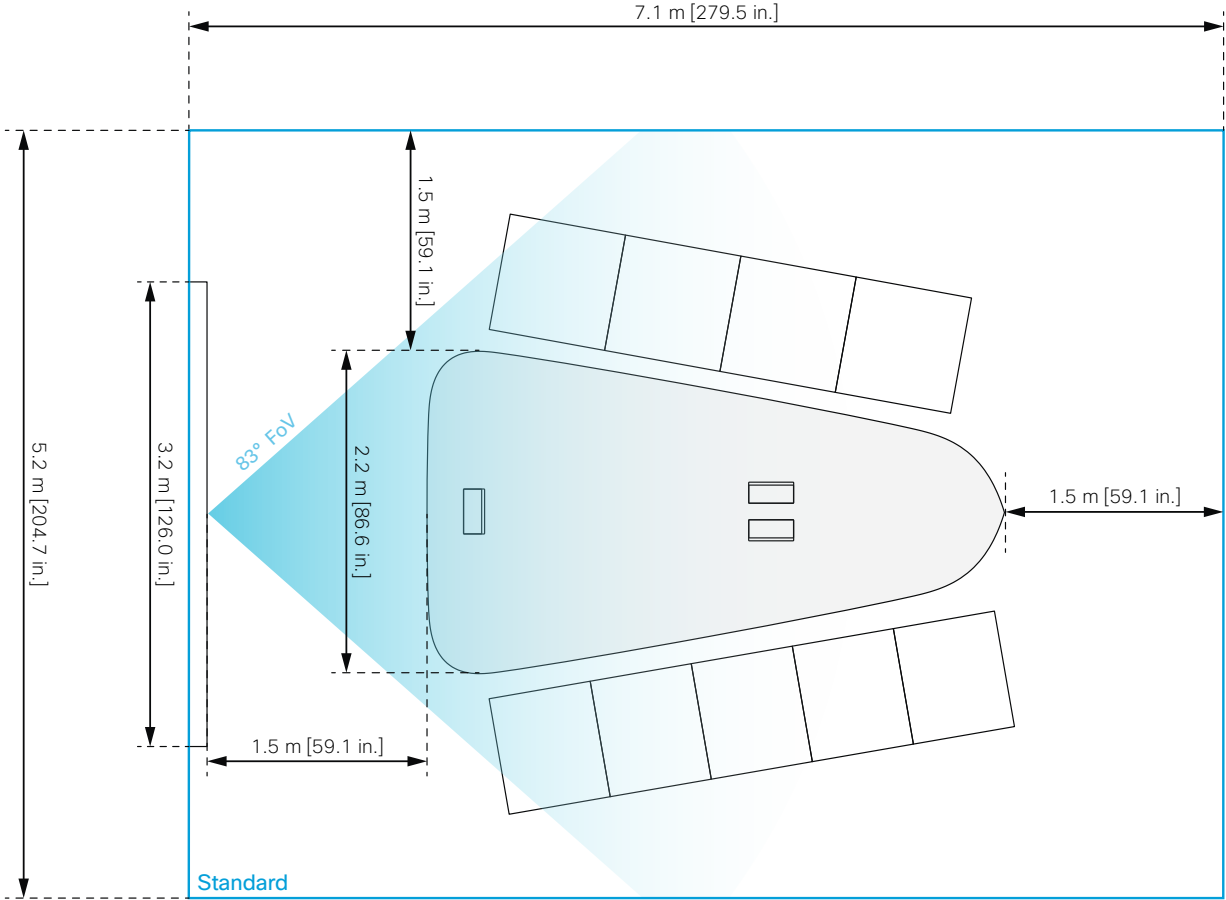

# Room dimensions for Room 70 Panorama (page 7 of 12)

Content screen above the main screens

## Number of persons:

- 2 × 4 seats → 80 cm [31.5 in.] per seat
- 2 × 5 seats → 70 cm [27.6 in.] per seat

## Recommended table width:

- 1.9 m [74.8 in.] (this page)
- 2.2 m [86.6 in.] (previous page)
- 2.5 m [98.4 in.] (two pages before)

## Minimum room height:

- 2.70 m [106.3 in.]

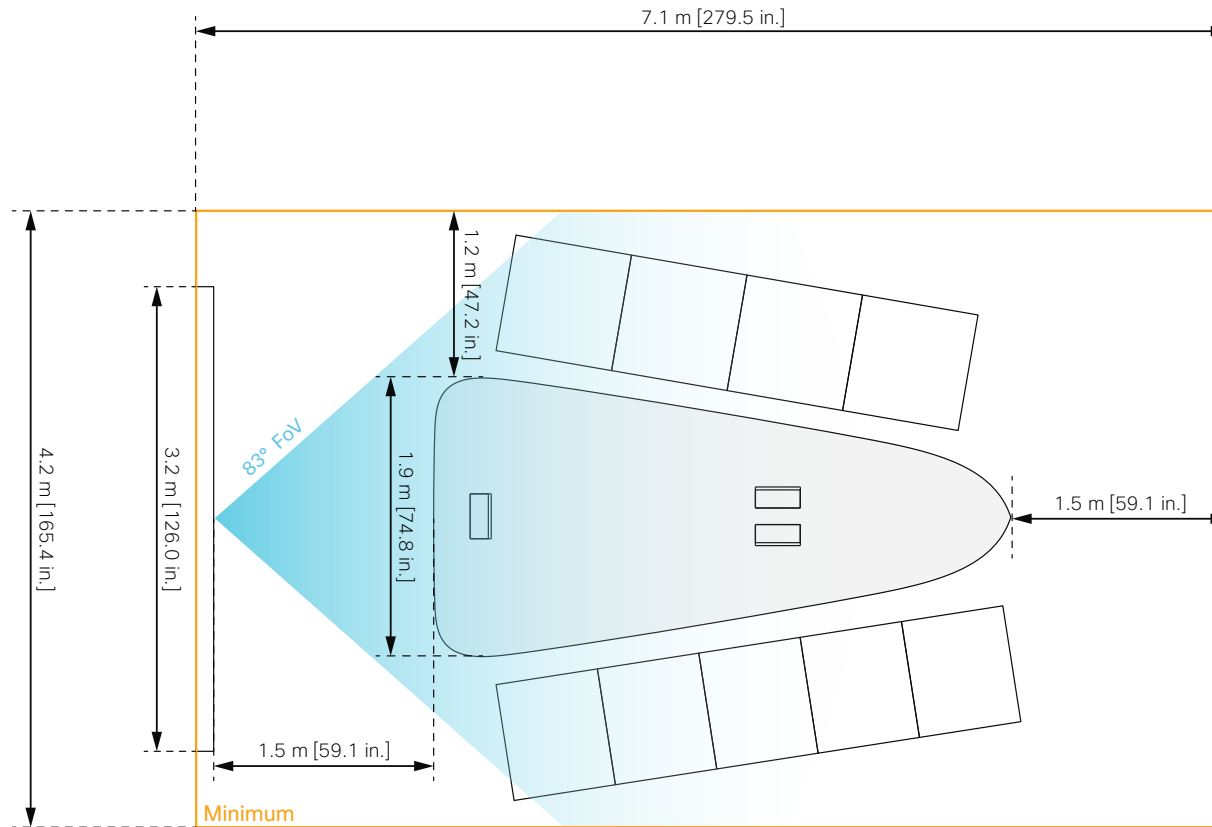

# Room dimensions for Room 70 Panorama (page 8 of 12)

Content screen above the main screens

## Number of persons:

- 2 × 3 seats → 80 cm [31.5 in.] per seat
- 2 × 4 seats → 70 cm [27.6 in.] per seat

## Recommended table width:

- 1.9 m [74.8 in.] (in two pages)
- 2.2 m [86.6 in.] (next page)
- 2.5 m [98.4 in.] (this page)

## Minimum room height:

- 2.70 m [106.3 in.]

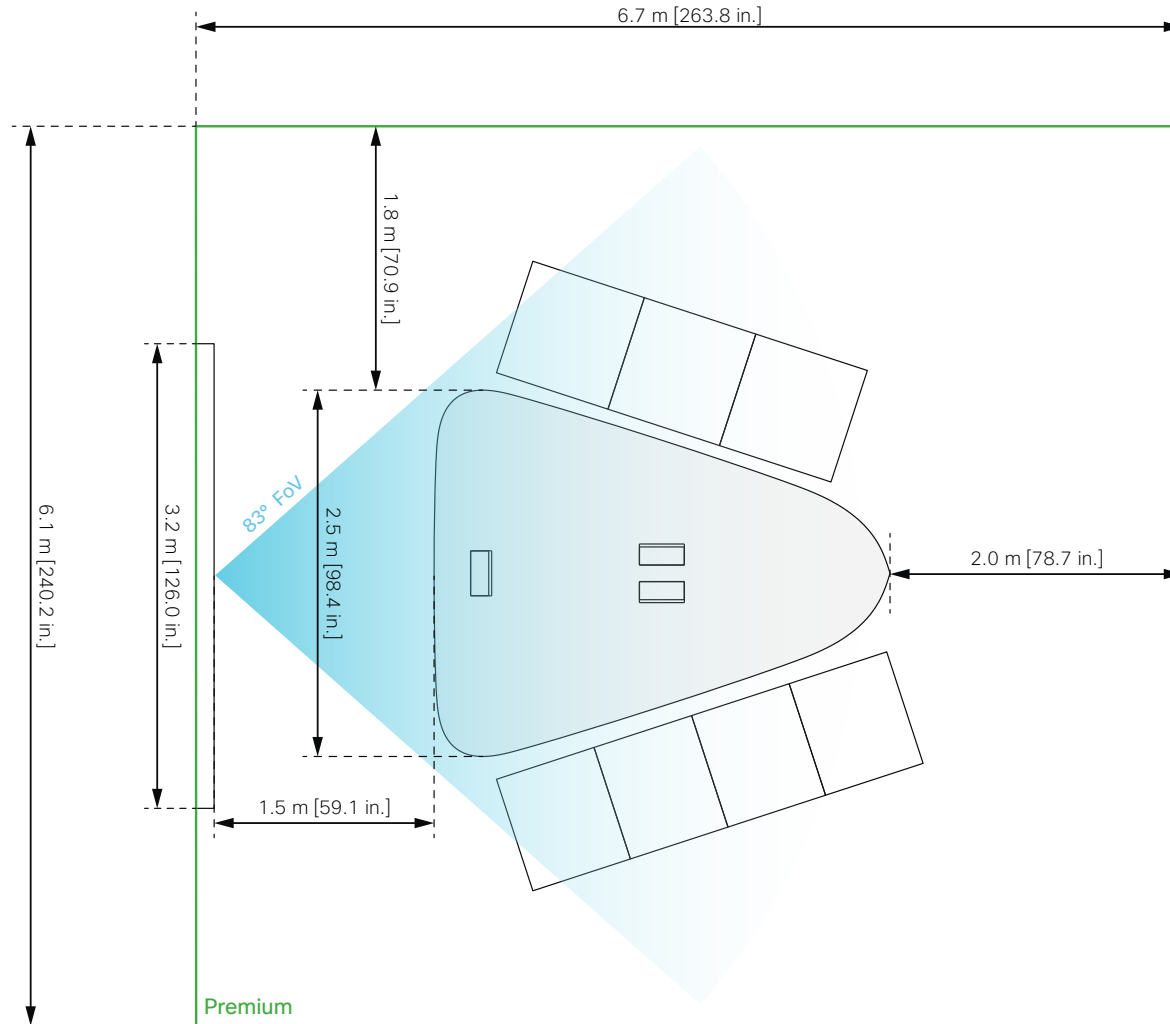

# Room dimensions for Room 70 Panorama (page 9 of 12)

Content screen above the main screens

## Number of persons:

- 2 × 3 seats → 80 cm [31.5 in.] per seat
- 2 × 4 seats → 70 cm [27.6 in.] per seat

## Recommended table width:

- 1.9 m [74.8 in.] (in two pages)
- 2.2 m [86.6 in.] (this page)
- 2.5 m [98.4 in.] (previous page)

## Minimum room height:

- 2.70 m [106.3 in.]

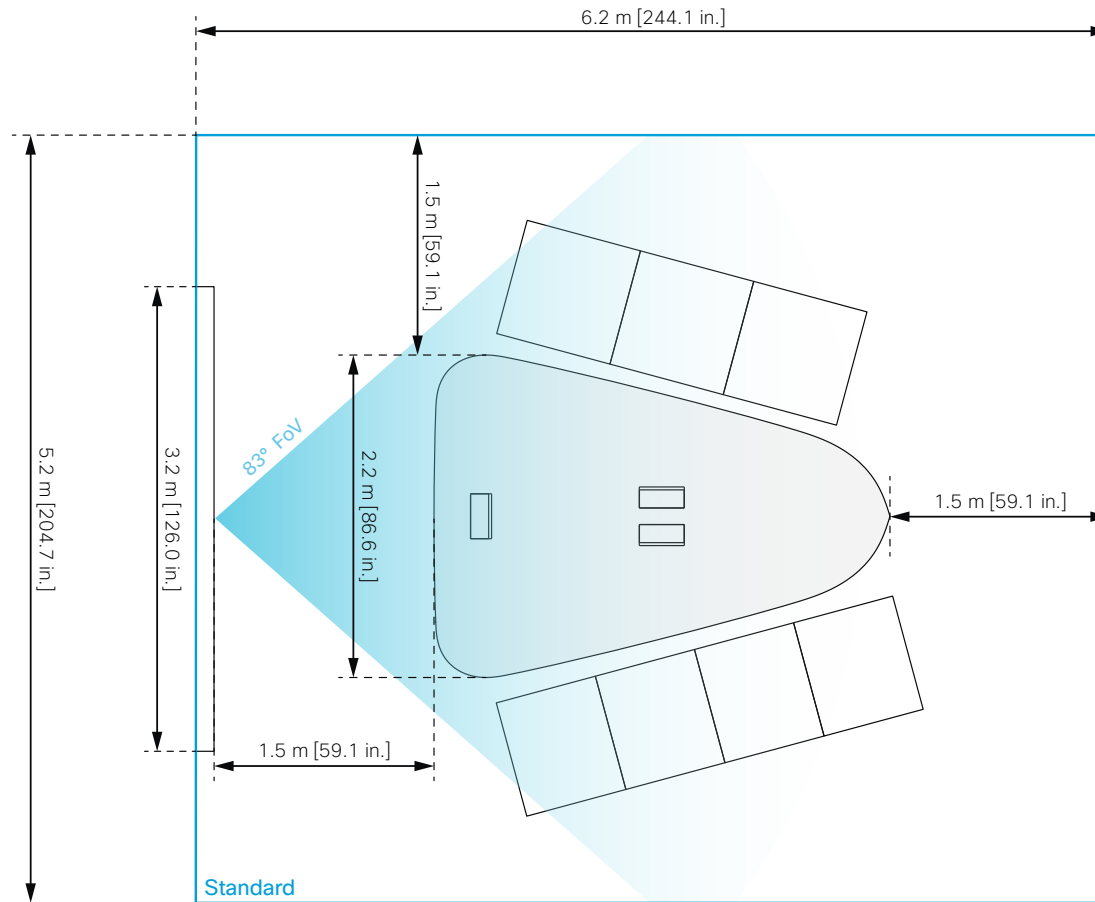

# Room dimensions for Room 70 Panorama (page 10 of 12)

Content screen above the main screens

## Number of persons:

- 2 × 3 seats → 80 cm [31.5 in.] per seat
- 2 × 4 seats → 70 cm [27.6 in.] per seat

## Recommended table width:

- 1.9 m [74.8 in.] (this page)
- 2.2 m [86.6 in.] (previous page)
- 2.5 m [98.4 in.] (two pages before)

## Minimum room height:

- 2.70 m [106.3 in.]

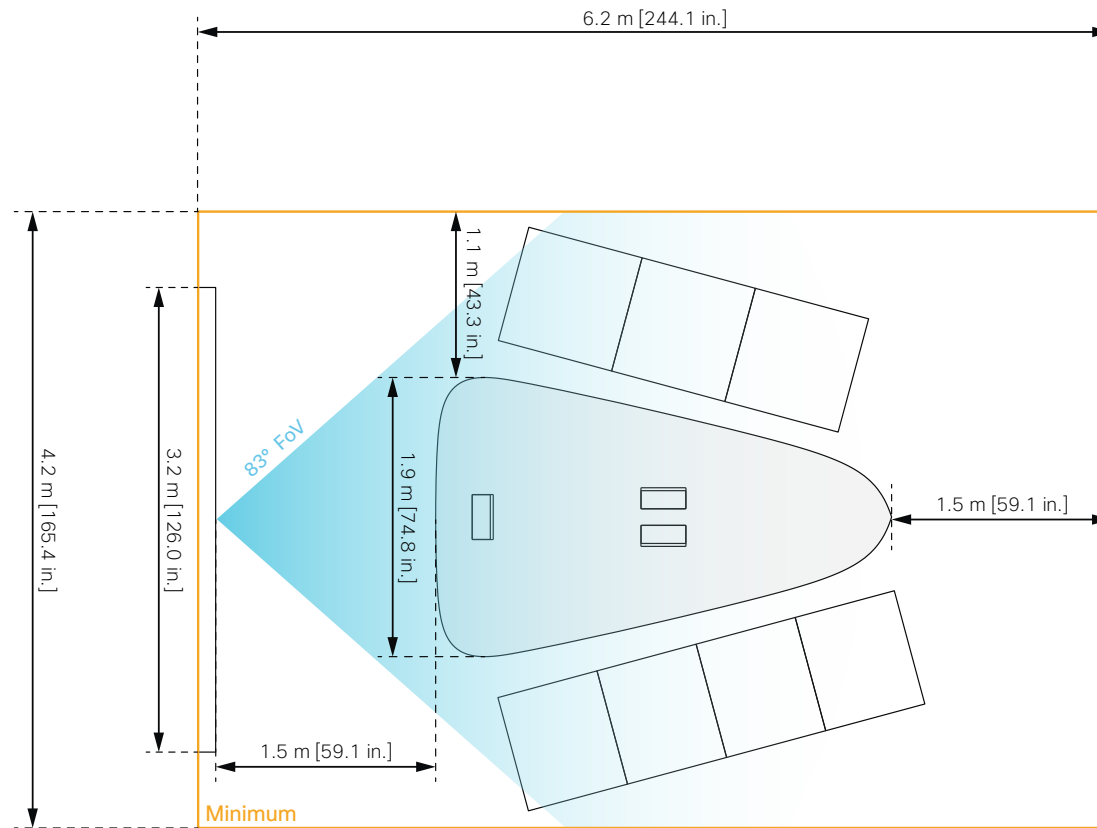



# Room dimensions for Room 70 Panorama (page 12 of 12)

Content screen below the main screens

**Number of persons:**

- 6 seats → 80 cm [31.5 in.] per seat

**Table:**

- Large classic table: 4.8 m [189.0 in.]

**Recommended room height:**

- 2.35 m [92.5 in.] or higher

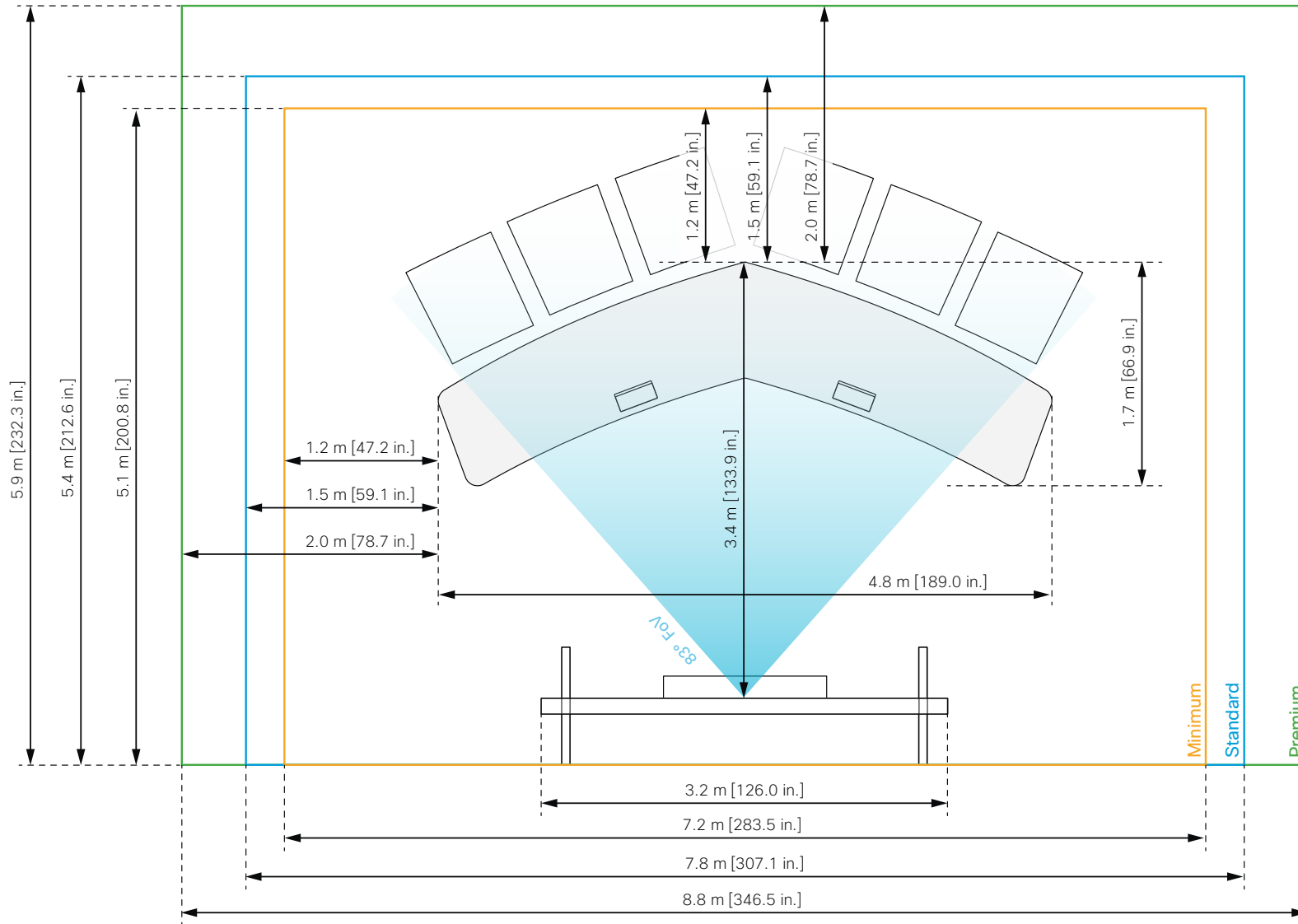



# Room dimensions for Room 70 Panorama in an IX5000 room (page 1 of 2)

Content screen above the main screens

## Number of persons:

- 2 × 3 seats → 80 cm (31.5 in.) per seat
- 2 × 4 seats → 70 cm (27.6 in.) per seat

## Recommended table width:

- 2.2 m [86.6 in.]

## Minimum room height:

- 2.70 m [106.3 in.]

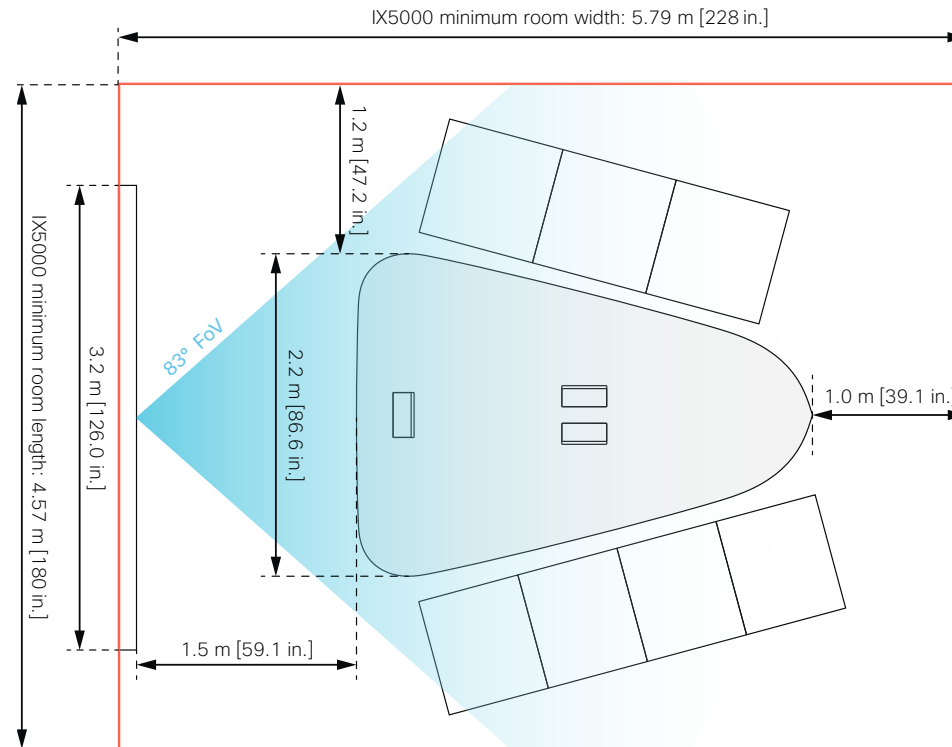

# Room dimensions for Room 70 Panorama in an IX5000 room (page 2 of 2)

Content screen below the main screens

## Number of persons:

- 6 seats → 75 cm (29.5 in.) per seat \*

## Table:

- Small classic table: 4.2 m [165.4 in.]

## Recommended room height:

- 2.35 m [92.5 in.] or higher

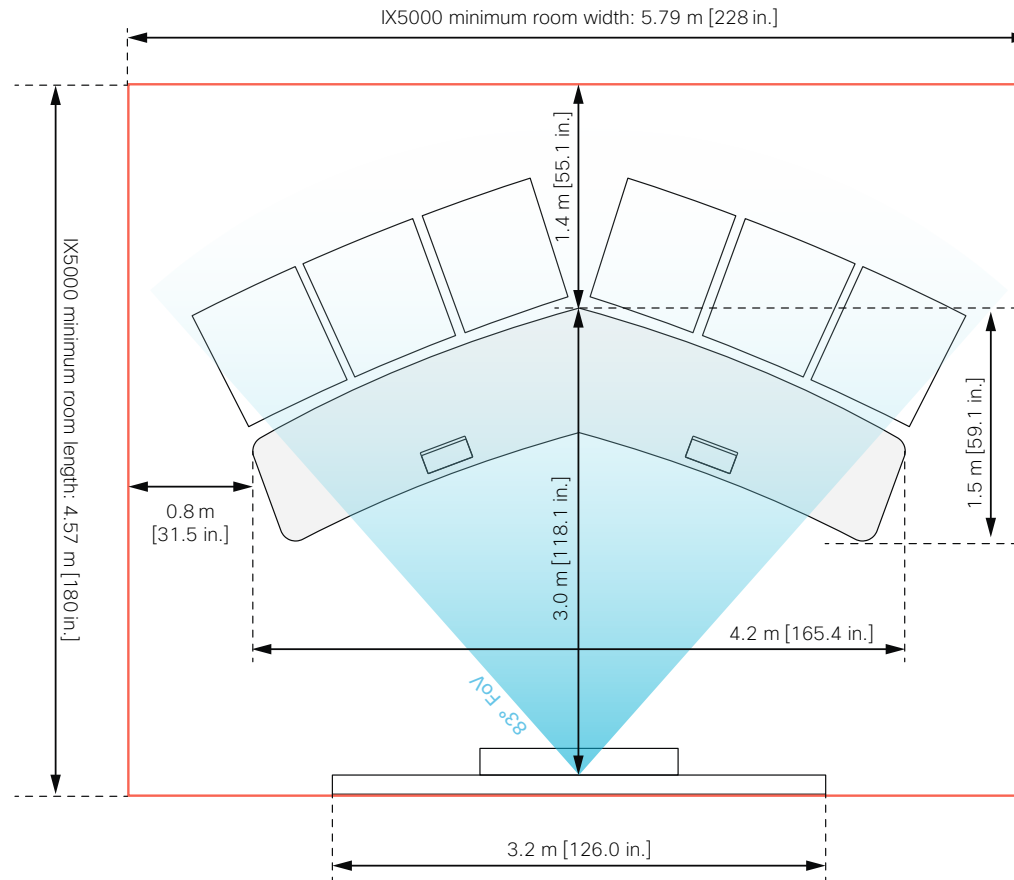

\* Note that 75 cm [29.5 in.] per seat requires the use of the entire table width. Work with the table supplier to ensure that the table legs do not prevent comfortable seating.

## Cosmetic wall panel finish

We offer optional cosmetic wall panels with two types of finish.

### ***Wooden panels (light oak)***

These panels are ready to use as shipped with the product.

### ***Ready-to-paint panels***

You have to paint the panels yourself.

The panels are produced with primer and then sanded with fine-grained paper. You should use water based carpentry paint, which is slightly harder and more glossy than normal wall paint.



*Cosmetic wall panel - wooden finish (light oak)*

## Building a custom wall (page 1 of 4)

You can integrate the Room Panorama system fully in the room by making your own custom wall integration instead of using the cosmetic wall panels that we offer. You still have to use the provided steel mounting structure and all the other components; it's only the cosmetic wall panels that are replaced by the custom wall.

### Additional requirements for a custom wall

The custom wall can be made in different ways, and using different types of materials. The installer must provide all materials, fasteners, and tools required to make and safely set up the wall.

**Read the following pages carefully to find which additional requirements there are for a custom wall.**

**Before you proceed with the custom wall planning and installation, we also recommend you to study the complete installation procedure in the *Room Panorama Installation Guide*. It's covered in Part 2, *Installing Room Panorama with a custom wall*.**



*Panorama with a Custom Wall*

# Building a custom wall (page 2 of 4)

## Depth and width of the wall

### *Depth*

The custom wall must level exactly at the same depth as the cosmetic wall panels provided by us. Otherwise the screen brackets and their hinge mechanism will not work. The hinge mechanism is required to allow access to the components behind the screens after the system is fully mounted.

Refer to the illustration for exact measurements.

### *Width*

The minimum wall width is 4.2 m (165.4 in.). It can be as wide as you like.

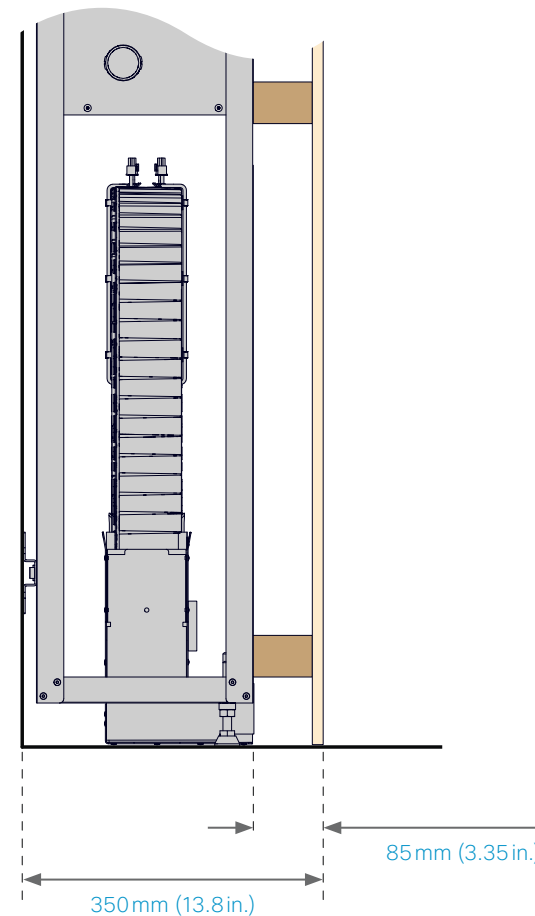

Side view with rails, risers, subwoofers, and cavities in place.

**The custom wall must level exactly as shown, 85 mm (3.35 in.) from the risers. This includes the wallboards or paneling.**

# Building a custom wall (page 3 of 4)

## Subwoofer output and air flow

### Air intake area and subwoofer output

The ventilation air intake is close to the floor. It aligns with the four subwoofers, which need an opening toward the room to provide excellent audio quality.

The opening must have the **exact** height and position as shown in the illustration.

You may have studs in front of some of the risers in the air intake area, as long as you don't cover the ducts from the subwoofers.

We provide subwoofer grille elements for the air intake area.

### Air outlet area

The ventilation air outlet is at the top. It is created with a gap or opening toward the ceiling. The **minimum** size is shown in the illustration.

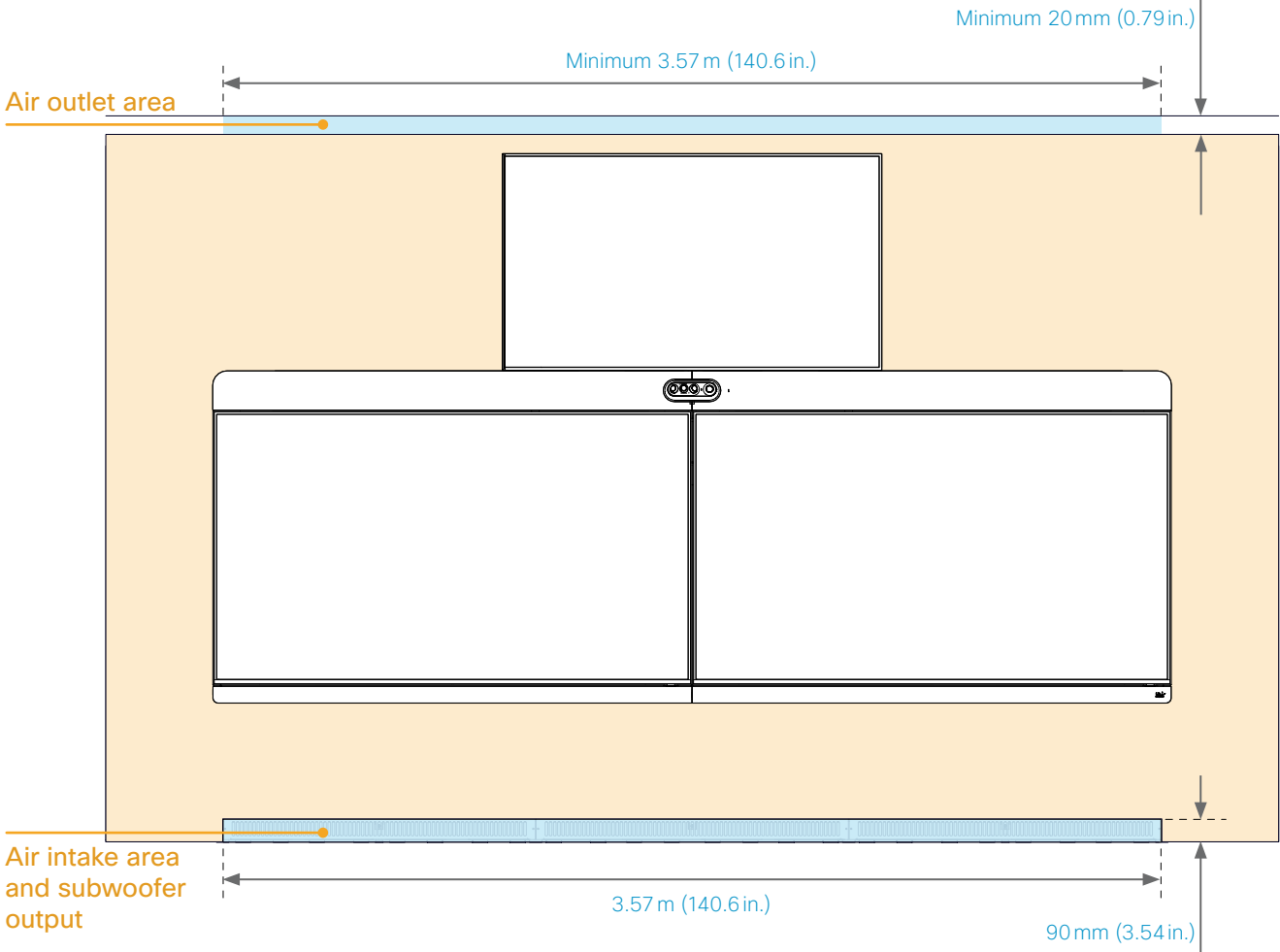

# Building a custom wall (page 4 of 4)

## Fastening the custom wall to the risers

The core mounting structure for the Room Panorama is the horizontal rails and vertical risers as shown in the illustration. This mounting structure must be securely fastened to the wall behind the system.

You may fasten the custom wall (studs) to the vertical risers. But take care not to cover up areas and holes that are needed when mounting the cavities and other components. These areas are marked with a color in the illustration.

## Color

The custom wall can have any finish that suites your room.

We recommend that you use a dark color, which goes well with the black metal parts, both for *screws* and custom *wall framework parts* that are visible when you tilt out or pull down the screens.

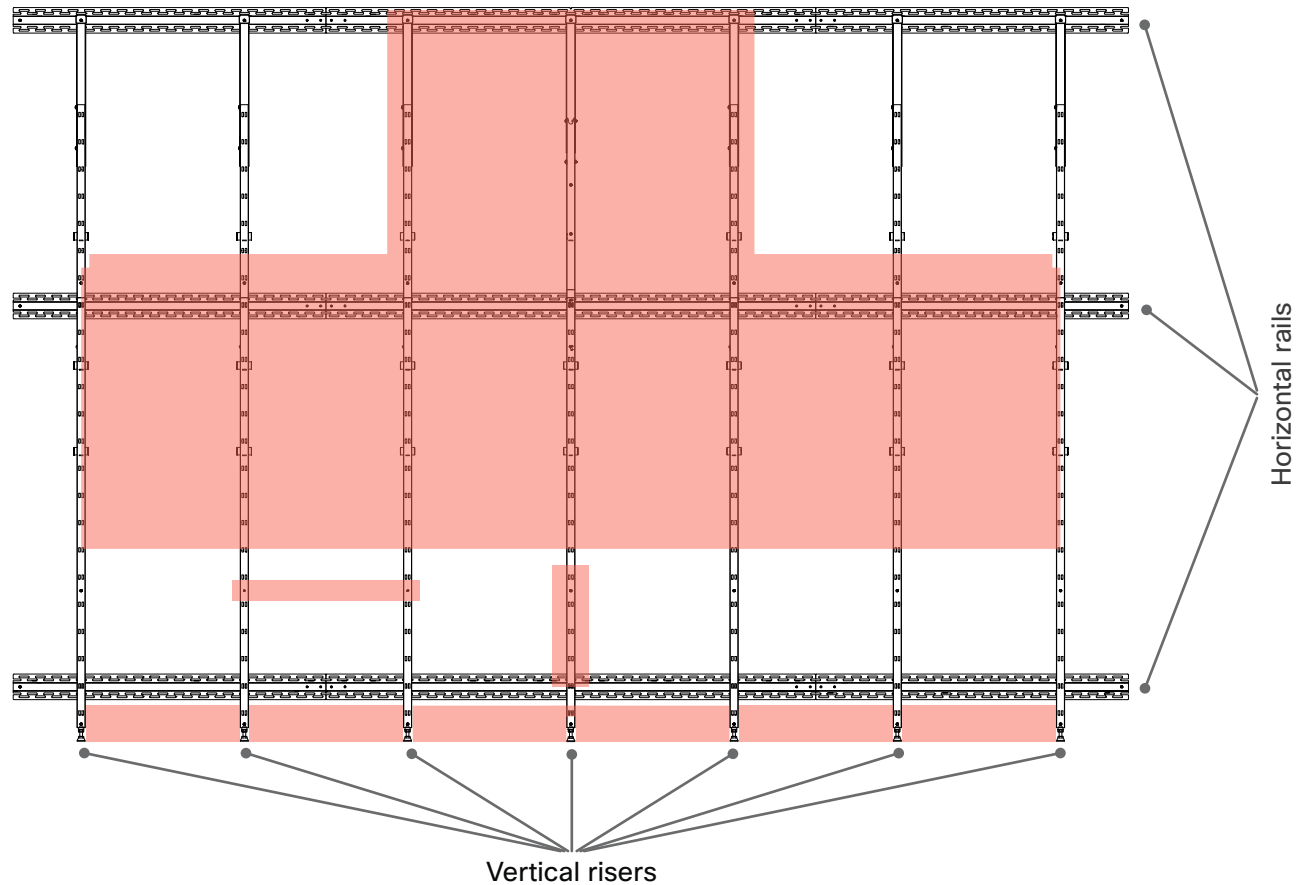

# Lighting example

## PowerBalance from Signify

- Glare-free dimmable light with tunable white and high uniformity
- Energy efficient LED light with long lifetime
- Versatile 60 × 60 mm tiles for exposed and concealed T-bar ceilings
- Luminaire controller with power over Ethernet

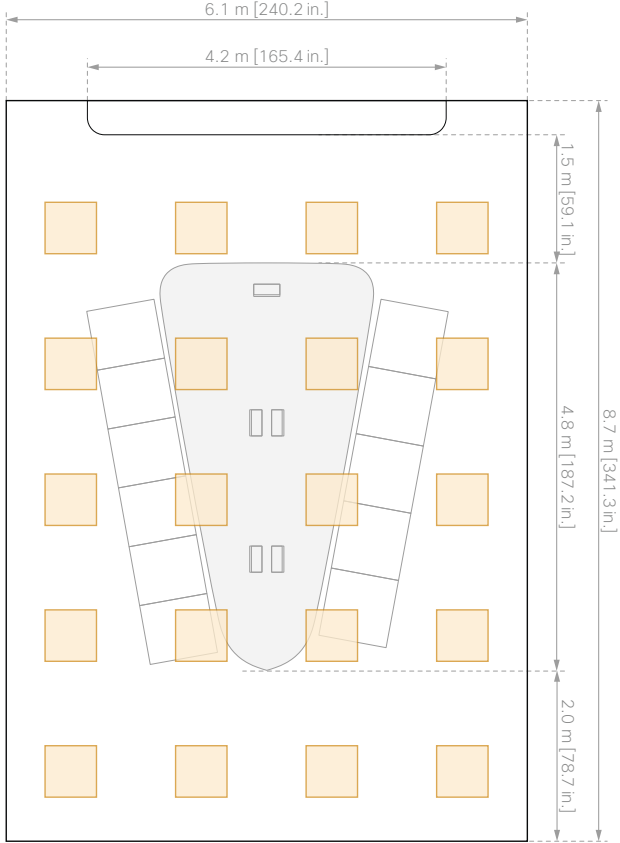

Example: Premium room with table for 10 persons





# Recommended vendors

The following list of vendors have met the testing and certification standards for Room Panorama deployment specifications.

We highly encourage using these vendors for Room Panorama as they will provide the most optimized meeting room experience.

If you would like to be a certified vendor for Room Panorama, and learn more about the *Webex Certification Program*, please visit:

<http://cs.co/rooms-certifications>

## Certified table vendors

### *Vitra International AG*

Website: vitra.com

Contact: pascal.berberat@vitra.com (direct)

Phone: CH +41 79 644 27 88 (direct)

Contact: ikam@vitra.com (team)

Phone: CH +41 61 377 00 00 (team)

### *Marshall Furniture*

Website: [www.marshallfurniture.com/custom-products/product-lines/tables/391-cisco-panorama-tables](http://www.marshallfurniture.com/custom-products/product-lines/tables/391-cisco-panorama-tables)

Contact: tom@marshallfurniture.com

### *Salamander Designs*

Website: [www.salamandercommercial.com/cisco/](http://www.salamandercommercial.com/cisco/)

Contact: custom@salamanderdesigns.com

### *Walter Knoll*

Website: [Walterknoll.de](http://Walterknoll.de)

Contact: Jan Sneiderger  
jan.sneiderger@walterknoll.de

## Certified chair vendors

### *Vitra International AG*

Website: vitra.com

Contact: pascal.berberat@vitra.com (direct)

Phone: CH +41 79 644 27 88 (direct)

Contact: ikam@vitra.com (team)

Phone: CH +41 61 377 00 00 (team)

### *Marshall Furniture*

Website: [www.marshallfurniture.com/custom-products/product-lines/tables/391-cisco-panorama-tables](http://www.marshallfurniture.com/custom-products/product-lines/tables/391-cisco-panorama-tables)

Contact: tom@marshallfurniture.com

## Certified room lighting vendors

### *Signify*

Website: [signify.com](http://signify.com)

## Certified acoustic panel vendors

### *DeAmp*

Website: [deamp.com](http://deamp.com)

## Intellectual property rights

THE SPECIFICATIONS AND INFORMATION REGARDING THE PRODUCTS IN THIS MANUAL ARE SUBJECT TO CHANGE WITHOUT NOTICE. ALL STATEMENTS, INFORMATION, AND RECOMMENDATIONS IN THIS MANUAL ARE BELIEVED TO BE ACCURATE BUT ARE PRESENTED WITHOUT WARRANTY OF ANY KIND, EXPRESS OR IMPLIED. USERS MUST TAKE FULL RESPONSIBILITY FOR THEIR APPLICATION OF ANY PRODUCTS.

THE SOFTWARE LICENSE AND LIMITED WARRANTY FOR THE ACCOMPANYING PRODUCT ARE SET FORTH IN THE INFORMATION PACKET THAT SHIPPED WITH THE PRODUCT AND ARE INCORPORATED HEREIN BY THIS REFERENCE. IF YOU ARE UNABLE TO LOCATE THE SOFTWARE LICENSE OR LIMITED WARRANTY, CONTACT YOUR CISCO REPRESENTATIVE FOR A COPY.

The Cisco implementation of CEP header compression is an adaptation of a program developed by the University of California, Berkeley (UCB) as part of UCB's public domain version of the UNIX operating system. All rights reserved. Copyright © 1981, Regents of the University of California.

NOTWITHSTANDING ANY OTHER WARRANTY HEREIN, ALL DOCUMENT FILES AND SOFTWARE OF THESE SUPPLIERS ARE PROVIDED "AS IS" WITH ALL FAULTS. CISCO AND THE ABOVE-NAMED SUPPLIERS DISCLAIM ALL WARRANTIES, EXPRESSED OR IMPLIED, INCLUDING, WITHOUT LIMITATION, THOSE OF MERCHANTABILITY, FITNESS FOR A PARTICULAR PURPOSE AND NONINFRINGEMENT OR ARISING FROM A COURSE OF DEALING, USAGE, OR TRADE PRACTICE.

IN NO EVENT SHALL CISCO OR ITS SUPPLIERS BE LIABLE FOR ANY INDIRECT, SPECIAL, CONSEQUENTIAL, OR INCIDENTAL DAMAGES, INCLUDING, WITHOUT LIMITATION, LOST PROFITS OR LOSS OR DAMAGE TO DATA ARISING OUT OF THE USE OR INABILITY TO USE THIS MANUAL, EVEN IF CISCO OR ITS SUPPLIERS HAVE BEEN ADVISED OF THE POSSIBILITY OF SUCH DAMAGES.

Any Internet Protocol (IP) addresses and phone numbers used in this document are not intended to be actual addresses and phone numbers. Any examples, command display output, network topology diagrams, and other figures included in the document are shown for illustrative purposes only. Any use of

actual IP addresses or phone numbers in illustrative content is unintentional and coincidental.

All printed copies and duplicate soft copies are considered un-Controlled copies and the original on-line version should be referred to for latest version.

Cisco has more than 200 offices worldwide. Addresses, phone numbers, and fax numbers are listed on the Cisco website at [www.cisco.com/go/offices](http://www.cisco.com/go/offices).

Cisco and the Cisco logo are trademarks or registered trademarks of Cisco and/or its affiliates in the U.S. and other countries. To view a list of Cisco trademarks, go to this URL: [www.cisco.com/go/trademarks](http://www.cisco.com/go/trademarks). Third-party trademarks mentioned are the property of their respective owners. The use of the word partner does not imply a partnership relationship between Cisco and any other company. (1110R)



---

Cisco Systems Inc.  
Corporate Headquarters  
170 West Tasman Dr.  
San Jose, CA 95134  
USA

<https://www.cisco.com>

---